

**Model CO
Compact Orifice
for Use with
Foxboro Differential Pressure Transmitters**
—
Style A

***Parts preceded by an asterisk are recommended spare parts.
Give Instrument Model Number and Style when ordering.
See Recommended Spare Parts Summary section for quantities.**

TO ORDER PARTS, CALL INVENSYS SYSTEMS INC. AT 1-866-746-6477.

MODEL CODES

Auxiliary Specification (AS) Code - Compact Orifice

Description (a)	AS Code
Compact Orifice with Integral 3-Valve Manifold	CO
Pipeline Size	
DN 15 or 1/2 inch Pipe	-HH
DN 25 or 1 inch Pipe	-11
DN 40 or 1 1/2 inch Pipe	-1H
DN 50 or 2 in Pipe	-22
DN 80 or 3 inch Pipe	-33
DN 100 or 4 inch Pipe	-44
Beta Ratio	
0.40	4
0.65	6
Alignment Ring	
For use with ANSI Flanges	A
For use with DIN Flanges	D
Example: AS Code CO-224A	

(a) Refer to AS Code CI if an optional installation kit is needed to assemble the orifice to the pipeline.

Auxiliary Specification (AS) Code - Optional Installation Kit

Description (a)	AS Code
Installation Kit for Compact Orifice (a)	CI
Pipeline Size	
DN 15 or 1/2 inch Pipe	-HH
DN 25 or 1 inch Pipe	-11
DN 40 or 1 1/2 inch Pipe	-1H
DN 50 or 2 in Pipe	-22
DN 80 or 3 inch Pipe	-33
DN 100 or 4 inch Pipe	-44
Flange Rating	
ANSI Class 150 Flange	AN150
ANSI Class 300 Flange	AN300
ANSI Class 600 Flange	A0600
DIN PN 16	PN016
DIN PN 40	PN040
DIN PN 100	PN100
Example: AS Code CI-22AN150	

(a) The optional installation kit includes the bolts, nuts, and gaskets required to assemble the Model CO to the pipeline.

FOXBORO TRANSMITTERS USED WITH THE COMPACT ORIFICE

Transmitter Model	Transmitter Description (a)	Communication Protocol	Parts List (PL) Number
IDP10	DP	FoxCom [®]	PL 009-005
IDP10	DP	HART [®]	PL 009-005
IDP10	DP	Fieldbus (b)	PL 009-005
IDP10	DP	Analog: 4 to 20 mA dc	PL 009-005
IDP10	DP	Analog: 1 to 5 V dc (Low Power)	PL 009-005
IDP25	Multirange (DP)	FoxCom, HART, and Fieldbus	PL 009-013
IDP50	Premium Performance (DP)	FoxCom, HART, and Fieldbus	PL 009-014
IMV25	Multivariable (DP, AP, and T)	FoxCom, HART, and Fieldbus	PL 009-019
IMV30	Multivariable (DP, AP, and T)	FoxCom and HART	PL 009-018

(a) DP = Differential Pressure; AP = Absolute Pressure; T = Temperature.

(b) Fieldbus = FOUNDATION[®] Fieldbus.

NOTE

The Model CO Compact Orifice is factory assembled to a calibrated transmitter and shipped as a unit ready for installation in a pipeline. However, the Model CO and applicable differential pressure transmitter are ordered separately. The Model Codes and parts relating to the applicable transmitter used are shown in the parts lists (PLs) listed in the table above.

**MODEL CO COMPACT ORIFICE ASSEMBLY (Figure 1)
SHOWN WITH d/p Cell® TRANSMITTER**

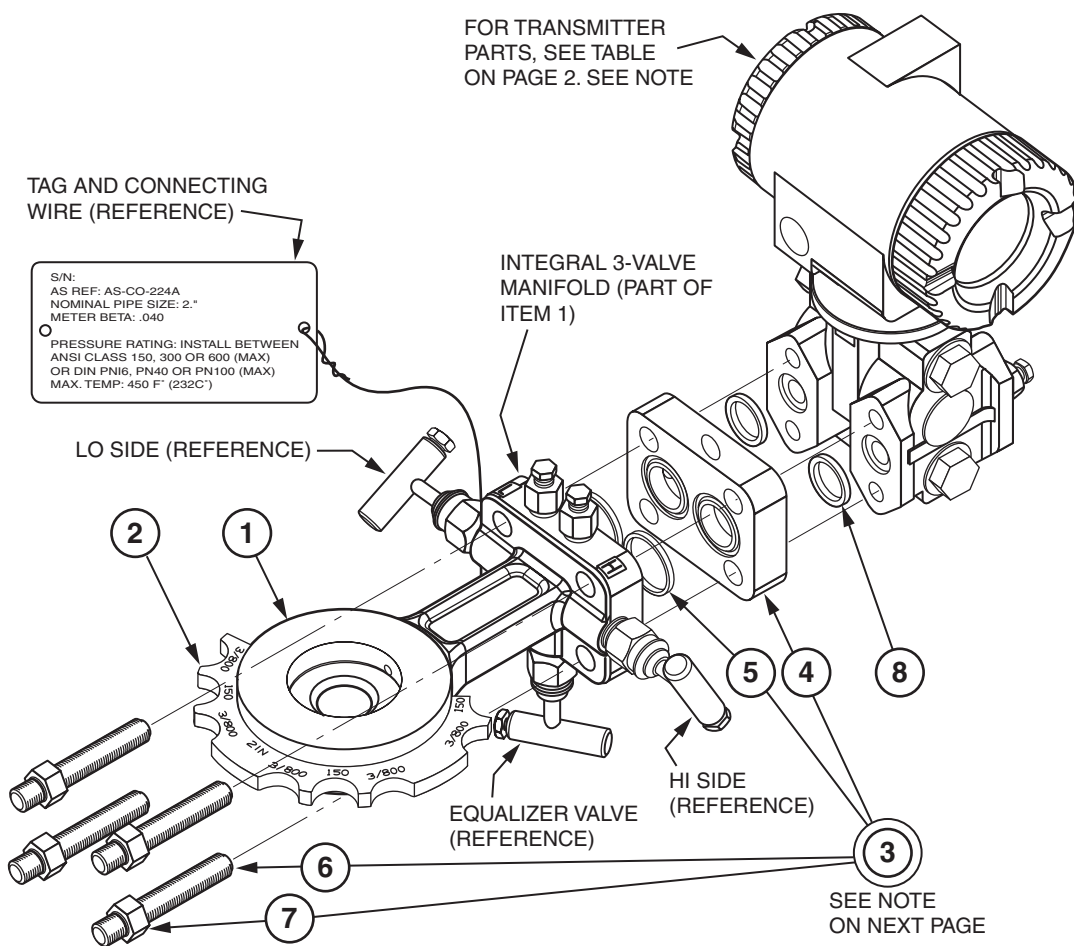

Item	Part No.	Qty.	Part Name
1	Below	1	Compact Orifice w/Integral 3-Valve Manifold
	D0176CA		DN 15 or 1/2 in Pipe; $\beta = 0.40$
	D0176CB		DN 15 or 1/2 in Pipe; $\beta = 0.65$
	D0176CE		DN 25 or 1 in Pipe; $\beta = 0.40$
	D0176CF		DN 25 or 1 in Pipe; $\beta = 0.65$
	D0176CJ		DN 40 or 1 1/2 in Pipe; $\beta = 0.40$
	D0176CK		DN 40 or 1 1/2 in Pipe; $\beta = 0.65$
	D0176CN		DN 50 or 2 in Pipe; $\beta = 0.40$
	D0176CP		DN 50 or 2 in Pipe; $\beta = 0.65$
	D0176CS		DN 80 or 3 in Pipe; $\beta = 0.40$
	D0176CT		DN 80 or 3 in Pipe; $\beta = 0.65$
	D0176CW		DN 100 or 4 in Pipe; $\beta = 0.40$
	D0176CX		DN 100 or 4 in Pipe; $\beta = 0.65$

MODEL CO COMPACT ORIFICE ASSEMBLY (Figure 1) (Cont.)

Item	Part No.	Qty.	Part Name
*2	Below	1	Alignment Ring, ANSI or DIN
	D0176DJ		1/2 in Pipe; ANSI Class 150/300/600 Flanges
	D0176FM		1 in Pipe; ANSI Class 150/300/600 Flanges
	D0176FP		1 1/2 in Pipe; ANSI Class 150/300/600 Flanges
	D0176FR		2 in Pipe; ANSI Class 150/300/600 Flanges
	D0176FT		3 in Pipe; ANSI Class 150/300/600 Flanges
	D0176FV		4 in Pipe; ANSI Class 150/300/600 Flanges
	D0176DK		DN 15 Pipe; DIN PN 16/40/100 Flanges
	D0176FN		DN 25 Pipe; DIN PN 16/40/100 Flanges
	D0176FQ		DN 40 Pipe; DIN PN 16/40/100 Flanges
	D0176FS		DN 50 Pipe; DIN PN 16/40/100 Flanges
	D0176FU		DN 80 Pipe; DIN PN 16/40/100 Flanges
	D0176FW		DN 100 Pipe; DIN PN 16/40/100 Flanges
3	D0176FL	Below	Adapter Kit, Orifice Assembly-to-Transmitter - Items 4 to 7 (see Note)
4	---	1	Adapter Plate, 316 ss
*5	D0176FZ	2	Gasket, Manifold-to-Adapter Plate, ptfе
6	D0176FY	4	Stud, 316 ss, A196 Gr. B8M, 0.4375-20 x 2.85
7	D0176FX	4	Nut, Hex head, 316 ss, A194 Gr. 8M, 0.4375-20
*8	D0114RB	2	Gasket, Adapter Plate-to-Transmitter, ptfе

— NOTE

The Model CO-to-Transmitter Adapter Kit (Item 3), comprises an adapter plate (Item 4), two gaskets (Item 5), four studs (Item 6) and four nuts (Item 7). The kit can be ordered in its entirety by specifying Part Number D0176FL, or the gaskets, studs, and nuts can be ordered separately for spare and replacement parts purposes.

FLANGE INSTALLATION KITS (Figure 2)

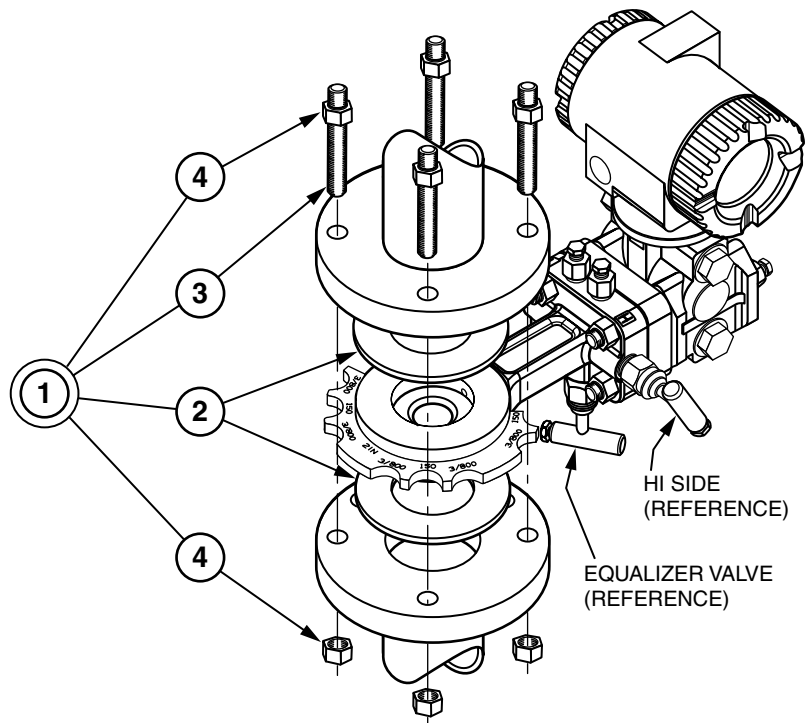

Item	Part No.	Qty.	Part Name
1	Tables 1 and 2	1	Flange Installation Kits, ANSI or DIN
2	Tables 1 and 2	2	Gasket, Flange; Durlon 8500 Aramid Fiber with NBR rubber binder
3	Tables 1 and 2	4 or 8	Stud, Plated Steel
4	Tables 1 and 2	8 or 16	Nut, Hex head, Plated Steel

Table 1. Flange Installation Kits - ANSI Flanges (a)

Pipe Size	ANSI Class	Kit Parts and Quantities			Item 1 Kit Part No.
		Item 2 Gasket	Item 3 Stud	Item 4 Nut	
1/2 in	150	2	4	8	D0176DL
	300	2	4	8	D0176DM
	600	2	4	8	D0176DN
1 in	150	2	4	8	D0176DS
	300	2	4	8	D0176DT
	600	2	4	8	D0176DU
1 1/2 in	150	2	4	8	D0176DY
	300	2	4	8	D0176DZ
	600	2	4	8	D0176EA
2 in	150	2	4	8	D0176EE
	300	2	8	16	D0176EF
	600	2	8	16	D0176EG
3 in	150	2	4	8	D0176EL
	300	2	8	16	D0176EM
	600	2	8	16	D0176EN
4 in	150	2	8	16	D0176ES
	300	2	8	16	D0176ET
	600	2	8	16	D0176EU

(a) See Table 2 for flange Installation Kits - DIN flanges.

Table 2. Flange Installation Kit - DIN Flanges

Pipe Size	DIN Rating	Kit Parts and Quantities			Item 1 Kit Part No.
		Item 2 Gasket	Item 3 Stud	Item 4 Nut	
DN15	PN 16	2	4	8	D0176DP
	PN 40	2	4	8	D0176DQ
	PN 100	2	4	8	D0176DR
DN 25	PN 16	2	4	8	D0176DV
	PN 40	2	4	8	D0176DW
	PN 100	2	4	8	D0176DX
DN 40	PN 16	2	4	8	D0176EB
	PN 40	2	4	8	D0176EC
	PN 100	2	4	8	D0176ED
DN 50	PN 16	2	4	8	D0176EH
	PN 40	2	4	8	D0176EJ
	PN 100	2	4	8	D0176EK
DN 80	PN 16	2	8	16	D0176EP
	PN 40	2	8	16	D0176EQ
	PN 100	2	8	16	D0176ER
DN 100	PN 16	2	8	16	D0176EV
	PN 40	2	8	16	D0176EW
	PN 100	2	8	16	D0176EX

RECOMMENDED SPARE PARTS SUMMARY

Figure Number	Item Number	Part Number	Part Name	Number of Parts Recommended for		
				1 Inst.	5 Inst.	20 Inst.
1	2	Below	Alignment Ring, ANSI or DIN	1	2	4
		D0176DJ	1/2 in Pipe, ANSI, Cl. 150/300/600 Flanges			
		D0176FM	1 in Pipe, ANSI, Cl. 150/300/600 Flanges			
		D0176FP	1 1/2 in Pipe, ANSI, Cl. 150/300/600 Flanges			
		D0176FR	2 in Pipe, ANSI, Cl. 150/300/600 Flanges			
		D0176FT	3 in Pipe, ANSI, Cl. 150/300/600 Flanges			
		D0176FV	4 in Pipe, ANSI, Cl. 150/300/600 Flanges			
		D0176DK	DN 15 Pipe, PN 16/40/100 Flange			
		D0176FN	DN 25 Pipe, PN 16/40/100 Flange			
		D0176FQ	DN 40 Pipe, PN 16/40/100 Flange			
		D0176FS	DN 50 Pipe, PN 16/40/100 Flange			
	D0176FU	DN 80 Pipe, PN 16/40/100 Flange				
	D0176FW	DN 100 Pipe, PN 16/40/100 Flange				
		5	D0176FZ (a)	Gasket, ptfe Manifold-to-Adapter Plate	2	4
	8	D0114RB	Gasket, ptfe Adapter Plate-to-Transmitter	2	4	10

(a) The manifold-to-adapter plate gasket can be ordered separately as indicated above, or the entire Adapter Kit (which includes two gaskets) can be ordered as indicated in Figure 1.

33 Commercial Street
Foxboro, MA 02035-2099
United States of America
www.foxboro.com
Inside U.S.: 1-866-746-6477
Outside U.S.: 1-508-549-2424
or contact your local Foxboro
representative.
Facsimile: 1-508-549-4999

Invensys, Foxboro, and d/p Cell are trademarks of Invensys plc, its subsidiaries, and affiliates.
All other brand names may be trademarks of their respective owners.

Copyright 2003 Invensys Systems, Inc.
All rights reserved

MB 150

Printed in U.S.A.

1003