

Model 75LBA Liquid Batcher



The Model 75LBA Liquid Batcher is a single loop, microprocessor-based instrument for use in applications where batching functions for liquids are required. An integral multi-function keypad allows local configuration and operator control.

FEATURES

- Pulse Input or 4 to 20 mA Input for Flow
- 4-wire Pt RTD or 4 to 20 mA Input for Temperature Compensation
- Control Inputs with Programmable Functionality for Remote Operation
- Display of Six-Digit Batch Total, Eight-Digit Running Total, Ten-Digit Grand Total and Six-Digit Rate
- Continuous Calculation of Density from Internal Density vs. Temperature Curve
- 4 to 20 mA Analog Output Configurable for Rate, Temperature, or Density
- Totalizer Pulse Output Coincident with Batch and Running Totals
- Two Relay Outputs for Batching Operations
- Three Configurable Alarm Outputs
- Local Configuration Using Multi-Function Keypad
- Easy to Read Fluorescent Display
- Panel- or Field-Mounted Versions
- Full Batching Functions with Top-Off Feature
- 120 V ac, 240 V ac, or 24 V dc
- Password Security for Configuration
- Ability to Internally Power all Input/Output Loops (ac Version only)

GENERAL DESCRIPTION

The 75LBA Liquid Batcher is a single loop, microprocessor based instrument for use with linear type flowmeters. It provides a fluorescent display of a six-digit batch total, eight-digit running total, ten-digit grand total, and six-digit rate. All totals and rate displays have programmable decimal points and alphanumeric labels to represent engineering units. Running total, grand total, and rate can be independently configured for any desired engineering units.

The primary inputs for flow are pulse (0 to 5 kHz) or analog (4 to 20 mA). This instrument also accepts a 4-wire Pt RTD or analog (4 to 20 mA) input proportional to temperature. The user may program a density vs. temperature curve, consisting of up to 20 points, into the instrument’s memory. The density is continuously calculated from this curve based upon the input temperature. Temperature and density can both be viewed on the display. Totals and rate can be displayed in volumetric, standard volumetric, or mass engineering units.

The 75LBA can perform batching functions using one (Manual) or two (Automatic) on/off valves. The user can program ramp-up or pre-warn values, as well as final batch size, in the Automatic mode as illustrated in Figure 1 below.

The batching capabilities of this instrument also include a top-off feature. This feature allows additional material to be added after a batch cycle has been completed by using the top-off key, or a control input programmed for that function. In the Manual mode, material is added by pressing the top-off key and keeping it depressed until finished. In the Automatic mode, a preset amount of material is added each time the top-off key is pressed.

Three outputs having programmable alarm set points are also provided. These outputs can be configured to act on batch total, running total, rate, temperature, and density.

Two control inputs are also provided. These inputs can be programmed to perform remote functions on the totalizer, rate, and batching operations. The same functions can also be performed locally using the integral keypad. The control inputs override keypad commands when activated.

The 75LBA Liquid Batcher can be provided in either a panel- or field-mounted enclosure. The front face of the panel-mounted version is sealed to NEMA 4X. The field-mounted enclosure meets the requirements of IEC IP65 and NEMA 4X.

SIMPLIFIED CONFIGURATION AND OPERATION

The 75LBA has two modes of operation – Run and Program. The Run Mode allows viewing of data, entering of alarm points, entering of batching parameters, and display of messages. Configuration of the instrument is done in the Program Mode, using the front panel keypad. A security passcode prevents unauthorized access to the Program Mode.

Configuration is accomplished by scrolling through the simple column and row format of the program menu structure. Submenus, or blocks, have been arranged into eight rows for easy understanding and accessibility. In addition, every block has a descriptive “help” message that explains what data to enter and how to enter it. The help message for any block can be displayed by pressing the help key when the prompt for that block appears on the display. This feature simplifies configuration. It is similar to having an instruction manual built into the instruments memory.

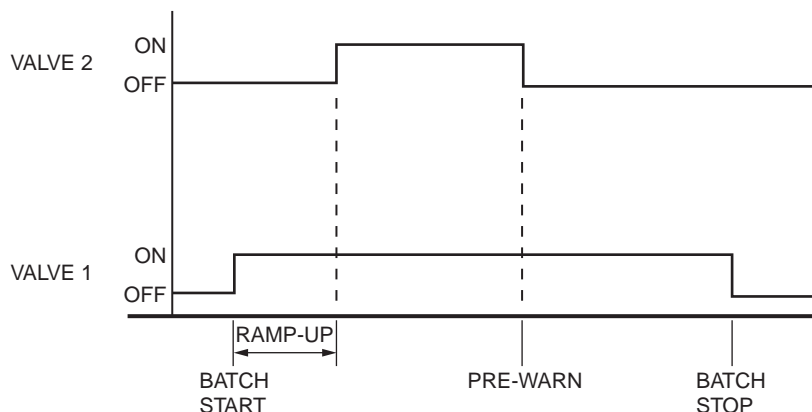

Figure 1. Ramp-Up, Pre-Warn, and Batch Size Functions

Quick access can be gained to any frequently changed block by entering the column and row location through the front panel.

OUTPUTS

The 75LBA can provide the following outputs simultaneously:

1. An analog output (4 to 20 mA) proportional to rate, density, or temperature.
2. A totalizer pulse output coincident with the least significant whole digit on the running totalizer.
3. Two relay outputs for batching operations (on/off valves).
4. Three outputs with associated alarm set points programmable for rate, temperature, density, running total, and batch total.

FRONT PANEL DISPLAY AND KEYPAD

This instrument can be configured and operated entirely from the front panel without the need for any external equipment. The front panel consists of an alphanumeric display and a keypad as shown in Figure 2 on page 4.

The fluorescent display consists of sixteen character positions. Each character is 5.1 mm (0.20 in) high and is comprised of 14 segments. The display provides an easy-to-read English language presentation of measurement values and engineering units.

Batch total, running total, grand total, rate, temperature, density, alarm output set points, and batching parameters (final, ramp-up, pre-warn) can all be displayed by the push of a key while in the Run Mode. Secondary parameters can be scrolled on the display using the \wedge key. Most parameter values will be displayed along with programmable alphanumeric labels that represent engineering units.

A default display can be programmed by the user. This display will automatically be shown on power-up, or on any exit from the Program Mode, or on demand by pressing the display key. This default display can be programmed to show either a single variable, or two variables simultaneously.

The keypad consists of 18 keys, many of which have dual functions. The keypad is used for mode selections (Run or Program Mode), configuration, and all operational requirements of the instrument. The use of each key is described in Table 1.

DIAGNOSTICS AND UPSET MESSAGES

The 75LBA automatically performs internal diagnostic tests upon a power-up. Any detected malfunctions will cause an error message(s) to be displayed. The instrument's operations are discontinued when a diagnostic malfunction is detected. The diagnostic tests can also be performed on demand from the Program Mode.

The 75LBA will also display alert messages if certain upset conditions (such as low flow, high flow, etc.), exist. The instrument's operations continue when these upset conditions are detected. The upset alert message will blink on the display, alternating with the normal data display, until corrected by the user.

PASSCODE SECURITY

Access to the Program Mode can be protected by a security passcode. This prevents unauthorized personnel from making configuration changes. Additionally, all front panel keys that are used to change alarm set points and batching parameters in the Run Mode can be selectively configured as open or locked. When configured as locked, parameter values cannot be changed by unauthorized personnel without first entering the Program Mode and reconfiguring the keys as open.

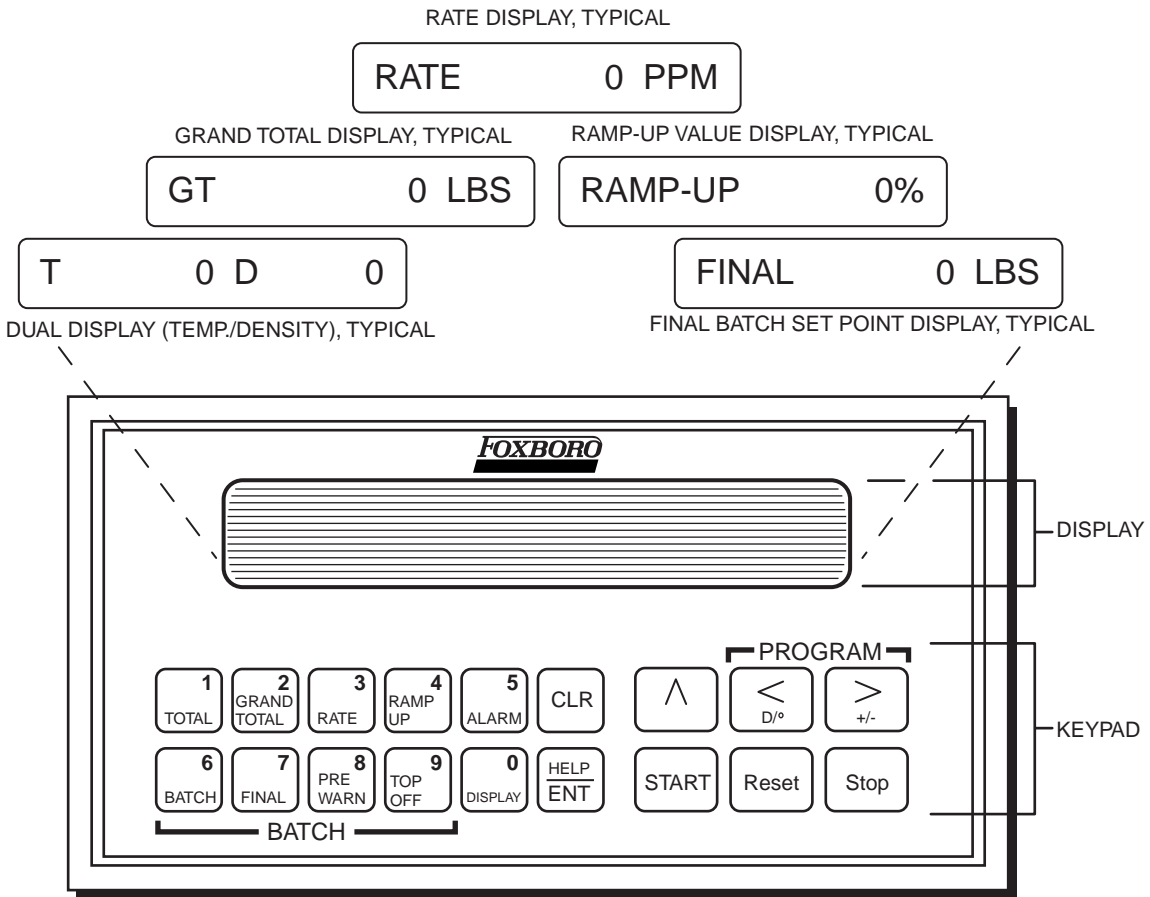

Figure 2. Front Panel Display and Keypad

Table 1. Keypad Description and Use



Key(s)	Usage of Multi-functional Keys in Run and Program Mode	
	Run Mode	Program Mode
 <p>1 TOTAL, 2 GRAND TOTAL, 3 RATE, 4 RAMP UP, 5 ALARM, 6 BATCH, 7 FINAL, 8 PRE WARN, 9 TOP OFF, 0 DISPLAY</p>	<p>The primary function of the number keys in the Run Mode is to enter new values for Alarm Points, Final Batch Set Point, Pre-Warn, and Ramp-Up.</p> <p>Each Number key is labeled showing its secondary function. These keys function as follows when pressed:</p> <p>[TOTAL] Displays the running total and engineering units (EGU). [GRAND TOTAL] Displays the grand total and EGU. [RATE] Displays the rate and EGU. [RAMP UP] Press to display or change the ramp up value in percent of final batch set point. [ALARM] Press to display or change alarm point values. [ALARM], [^] Press this sequence of keys to select Alarm Output 1, 2, or 3. [BATCH] Displays the batch total and EGU. [FINAL] Press to display or change the final batch set point. [PRE WARN] Press to display or change the pre-warn value in percent of final batch set point. [TOP OFF] Initiates the top-off function. In manual mode, the output relay remains open for as long as this key is pressed. In automatic mode, a preset amount (as configured in the Program Mode) is added each time this key is pressed. [DISPLAY] Displays the programmable default parameters. The default display is shown after power-up and whenever the Program Mode is exited.</p>	<p>Press to:</p> <ul style="list-style-type: none"> • Enter a numerical value for block parameters. • Directly enter a specific menu block instead of using the ^, <, or > keys. • Access to layered (z-axis) parameters within some blocks.
	<p>Press to clear the old parameter value from memory before entering the new value.</p>	<p>Press to clear the old parameter value from memory before entering the new value.</p>

Table 1. Keypad Description and Use (Continued)





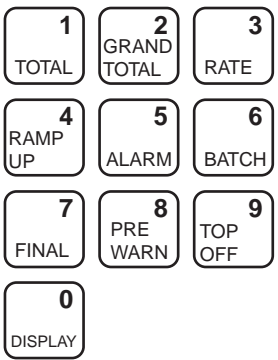

Key(s)	Usage of Multi-functional Keys in Run and Program Mode	
	Run Mode	Program Mode
	Press [ENT] to enter a keyed-in parameter value into memory.	Press [HELP] to scroll through help messages for any submenu block. For ease of reading, simply press the \wedge key to stop scrolling of the desired message. Press this key again to restart the scroll. To end scrolling and return to the submenu prompt, press any other key. Press [ENT] to enter a keyed-in parameter value into memory.
	Functions: <ul style="list-style-type: none"> • Press and release to display labels for default displays. • Press and hold for 2 seconds to change a default display. • Press simultaneously with [>] to enter the Program Mode. 	[<] Functions: Press to: <ul style="list-style-type: none"> • Scroll backward between submenus within a row. • Select a parameter or character from a submenu block. The selection is indicated by a blinking parameter on the display. • Adjust the current trim in submenu 28. [D/°] Function: Press to show decimal point (if required) when entering a new parameter value with number keys.
	Press simultaneously with [<] to enter the Program Mode.	[>] Functions: Press to: <ul style="list-style-type: none"> • Scroll forward between submenus within a row. • Select a parameter or character from a submenu block. The selection is indicated by a blinking parameter or character on the display. • Adjust the current trim in submenu 28. [+/-] Function: Press to indicate a negative value for temperature.
	Press simultaneously to enter the Program Mode.	Press simultaneously to return to the "PROGRAM?" prompt from any submenu block.

Table 1. Keypad Description and Use (Continued)

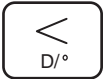
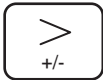
Key(s)	Usage of Multi-functional Keys in Run and Program Mode	
	Run Mode	Program Mode
	Press to: <ul style="list-style-type: none"> • Scroll through values for secondary parameters. • Scroll through default display options after [<] has been pressed for 2 seconds. • Select Alarm Output 1, 2, or 3 after [ALARM] has been pressed for 2 seconds. 	Press to: <ul style="list-style-type: none"> • Scroll between menu rows when a "PROGRAM?" or "ROW" indicator prompt is displayed. • Select a menu option from a submenu block. • Pause or restart a help message scroll on the display. • Change data pair number for temperature/density or k/frequency in submenus 12 and 21. Press repeatedly to Run diagnostics in submenu 85.
	Press to initiate or re-start a batching operation.	This key has no function in the Program Mode.
	Press to perform programmed functions on total, rate, and batch operations.	Press to: <ul style="list-style-type: none"> • Exit the Program Mode when the "PROGRAM?" prompt is displayed. • Answer "YES" or "NO" to parameter options within submenus 54 through 57. • Initiate analog input calibration for temperature in submenu 15.
	Press to stop a batching operation.	This key has no function in the Program Mode.

MODEL CODE

Description	Code
Liquid Batcher	75LBA
Enclosure	
Panel Mounting	-PD
Field Enclosure, Surface Mounting	-FE
Field Enclosure, Pipe Mounting	-FF
Language	
English	E
Nominal Supply Voltage and Frequency	
120/240 V ac, 50/60 Hz; 24 V dc	F
Input Signal	
Pulse Primary Flow Input Signal, 0 to 5 kHz	A
Analog Primary Flow Input Signal, 4 to 20 mA	B
Example: 75LBA-PDEFB	

OPERATING, TRANSPORTATION, AND STORAGE CONDITIONS

Influence	Reference Operating Conditions	Normal Operating Condition Limits	Transportation and Storage Limits
Ambient Temperature	25 °C ±2°C (77 °F ±3°F)	0 and 50°C (32 and 122°F)	-40 and +70°C (-40 and +158°F)
Relative Humidity	50% ±10%	0 and 85% Noncondensing	0 and 85% Noncondensing
Supply Voltage (ac)	120 or 240 V ac ±1 V ac	Rated Voltage +10% and -15%	Not Applicable
Supply Frequency (ac)	50 or 60 Hz ±0.5 Hz	Rated Frequency ±3 Hz	Not Applicable
Supply Voltage (dc)	24 V dc ±0.5 V dc	18 and 27 V dc	Not Applicable
RFI Susceptibility	3 V/m from 27 to 1000 MHz	3 V/m from 27 to 1000 MHz	Not Applicable
Vibration	Negligible	Up to 200 Hz at an acceleration of 5 m/s ² (1/2 "g")	200 Hz at an acceleration of 5 m/s ² (1/2 "g")

PERFORMANCE SPECIFICATIONS

Accuracy - Pulse Input Version

Parameter	Under Reference Operating Conditions	Under Normal Operating Condition Limits
Analog Output	±0.1% of Span	±0.25% of Span
Rate Display	±0.015% of Rate	±0.015% of Rate
Temperature Input	±0.1% of Span	±0.25% of Span

Accuracy - Analog Input Version

Parameter	Under Reference Operating Conditions	Under Normal Operating Condition Limits
Analog Input	±0.1% of Span	±0.25% of Span
Analog Output	±0.2% of Span	±0.50% of Span
Temperature Input	±0.1% of Span	±0.25% of Span
Rate Display	Same Accuracy as input ±0.015% of Rate	
Total Display	Same Accuracy as input ±1 Update	

STANDARD SPECIFICATIONS

Rateometer

TYPE

1/TAU

DISPLAY

6 digits with 3 alphanumeric characters of measurement identifier

TRENDING

0.5 to 7.5 seconds in 0.5 second increments

Totalizers

BATCH TOTALIZER

Displays 6 digits in same EGUs as running total

RUNNING TOTAL

Displays 8 digits with 3 alphanumeric characters of measurement identifier

GRAND TOTAL

Displays 10 digits with 3 alphanumeric characters of measurement identifier

Power

120 V ac, +10%, -15%, 50/60 Hz, 0.2 A maximum;

240 V ac, +10%, -15%, 50/60 Hz, 0.1 A maximum;

18 to 27 V dc, 0.4 A maximum, 5 W maximum

Panel Mounted Enclosure

Noryl enclosure with polyester front panel. The panel-mounted instrument can be mounted flush on a control rack or panel. Instrument front face is sealed to provide the environmental protection of NEMA Type 4X.

Field Mounted Enclosure

The panel mounted instrument is mounted flush in the door of a glass-filled polyester enclosure with a baked gray finish. The field-mounted enclosure may be mounted to a surface or to a nominal DN 50 or 2-inch pipe. It meets the requirements of NEMA Type 4X.

Wiring Connections

PANEL-MOUNTED ENCLOSURE

Five terminal blocks are located on rear surface of enclosure. These terminal blocks accommodate all input and output terminations.

FIELD-MOUNTED ENCLOSURE

Same as for panel mounted instrument. Access to terminal blocks obtained by opening enclosure door. Conduit entry ports and openings to be provided by user.

Agency Approvals

The 75LBA has been approved by CSA for use in general purpose (ordinary) locations.

Approximate Mass

PANEL MOUNTED UNIT

0.8 kg (1.75 lb)

FIELD MOUNTED UNIT

4 kg (8.8 lb)

Inputs

PULSE (FLOW)

0 to 5 kHz; 2.8 to 40 V p-p, 50 μ s minimum width

ANALOG (FLOW)

4 to 20 mA

CONTROL

Quantity

Three

Type

Requires current sinking device such as contact closure to ground, or NPN transistor to ground.

Impedance

5.8 k Ω to +5 V dc

Voltage

High = 3.5 to 24 V dc

Low = 0.0 to 1.0 V dc

Bounce

30 ms, minimum

RTD (TEMPERATURE)

Type

4-wire RTD, Pt to ASTM Curve

Impedance

100 Ω

Response

2 Hz

Resolution

14 bits

Range

-320 to 850°F

ANALOG (TEMPERATURE)

4 to 20 mA

STANDARD SPECIFICATIONS (Cont.)

Outputs

ANALOG

4 to 20 mA optically isolated; 12 to 27 V dc compliance voltage; 2 Hz response; programmed to be proportional to displayed rate, temperature, or density

TOTALIZER PULSE

Type

1 NPN transistor

Rating

150 mA maximum, 30 V dc blocking maximum

Operation

Outputs one pulse for every increment of least significant whole digit on BATCH and RUNNING TOTALS. The output pulse width is selectable from:

Fast: 125 μ s width, 1.5 kHz maximum

Medium: 2 ms width, 200 Hz maximum

Slow: 50 ms width, 10 Hz maximum

POWER

24 V dc \pm 5%, 100 mA maximum

ALARMS

Quantity

Three

Type

NPN transistors assignable to Hi/Lo limits for rate, temperature, density, or batch total. Also assignable as \geq running total.

Rating

Same as for totalizer pulse

Operation

Follows, timed (0.01 to 99.99 seconds), or latched

RELAY OUTPUTS

Quantity

2 relays dedicated to the batching operation.

Relay K2 is dedicated to Valve 1 and Relay K1 is dedicated to Valve 2 in Automatic mode.

Contacts

Single form C, 240 V ac, 5 A, resistive; or

24 V dc, 5 A, resistive

TECHNICAL INFORMATION⁽¹⁾

PULSE INPUT VERSION

The 75LBA accepts a pulse input (0 to 5 kHz) from the flowmeter. The ratio of the input pulses per unit of measure is defined by the programmed value for the flowmeter K factor. The K factor can be entered as a single value, or linearized over a range of input frequencies. If linearized, up to 20 data pairs (K, f), representing a K vs. f curve, can be entered into memory. The K value is calculated every 35 milliseconds (ms) based on the current value of "f".

The totalized value is updated every 140 ms (dt) using the following formulas:

Uncompensated Total =

$$Total + \left(C_i \times \frac{f}{K} \times dt \right)$$

Compensated (std. vol) Total =

$$Total + \left(C_i \times \frac{\rho}{\rho_{std}} \times \frac{f}{K} \times dt \right)$$

Compensated (mass) Total =

$$Total + \left(C_i \times \rho \times \frac{f}{K} \times dt \right)$$

where: i = 2 for Running Total
 i = 3 for Grand Total

The programmed values for C₂ and C₃ multipliers allow the user to display Running and Grand totals independently in any desired unit of measure.

Each total display has a programmable decimal point. The totalizer pulse output is coincident with the least significant whole digit on the Running Total display. The totalizers count in positive increments only (totals are always cumulative). Totals can be reset by pressing the RESET key and/or activating a control input programmed for that purpose.

Flow rate is calculated every 140 milliseconds and the rate display/output updated every 1/2 second using the equations:

Uncompensated Rate =

$$C_4 \times T_{base} \times \frac{f}{K}$$

Compensated (std. vol) Rate =

$$C_4 \times T_{base} \times \frac{\rho}{\rho_{std}} \times \frac{f}{K}$$

Compensated (mass) Rate =

$$C_4 \times T_{base} \times \rho \times \frac{f}{K}$$

The number of rate updates averaged together to update the display and analog output is determined by the value programmed for the trending time. The time base (T_{base}) can be programmed for seconds, minutes, hours, or days. The C₄ Multiplier can be programmed to display rate in any desired units of measure independent of the totalizers. The rate display has a programmable decimal point.

Rate and totals can be displayed in standard volumetric or mass engineering units. The 75LBA accepts an RTD or 4 to 20 mA analog input for temperature for this purpose. A density vs. temperature curve, consisting of up to 20 data pairs (ρ, T), can be entered into memory. Density is calculated approximately every 1/2 second based on the current value for temperature, and will be used in the flow rate and totalizer equations. To accurately display rate and totals in volumetric engineering units, the product density at standard conditions must also be entered into memory.

The 75LBA alarms can be configured for flow rate, temperature, and/or density measurements. Alarms acknowledgement is by means of the RESET key and/or a control input programmed for that purpose.

(1) Symbology used in equations is taken from R. W. Miller's "Flow Measurement Engineering Handbook". This handbook is available from Foxboro and is identified as Foxboro Part Number B0150YW.

TECHNICAL INFORMATION (Cont.)
ANALOG INPUT VERSION

With the exception of characteristic formulas, the analog input version (flow) functions basically the same as the pulse input version previously described. The formulas for the analog input version are shown below.

Uncompensated Total =

$$Total + \left(C_i \times Q_{input} \times \frac{dt}{T_{base\ in}} \right)$$

Compensated Total (std. vol.) =

$$Total + \left(C_i \times Q_{input} \times \frac{dt}{T_{base\ in}} \times \frac{\rho}{\rho_{std}} \right)$$

Compensated Total (mass) =

$$Total + \left(C_i \times Q_{input} \times \frac{dt}{T_{base\ in}} \times \rho \right)$$

where: i = 2 for Running Total
 i = 3 for Grand Total

Uncompensated Rate =

$$Q_{input} \times \frac{T_{base\ out}}{T_{base\ in}} \times C_4$$

Compensated Rate (std. vol.) =

$$Q_{input} \times \frac{T_{base\ out}}{T_{base\ in}} \times C_4 \times \frac{\rho}{\rho_{std}}$$

Compensated Rate (mass) =

$$Q_{input} \times \frac{T_{base\ out}}{T_{base\ in}} \times C_4 \times \rho$$

PROGRAM MENUS

Program menus for the pulse input and analog input versions are shown in Figures 3 and 4, respectively.

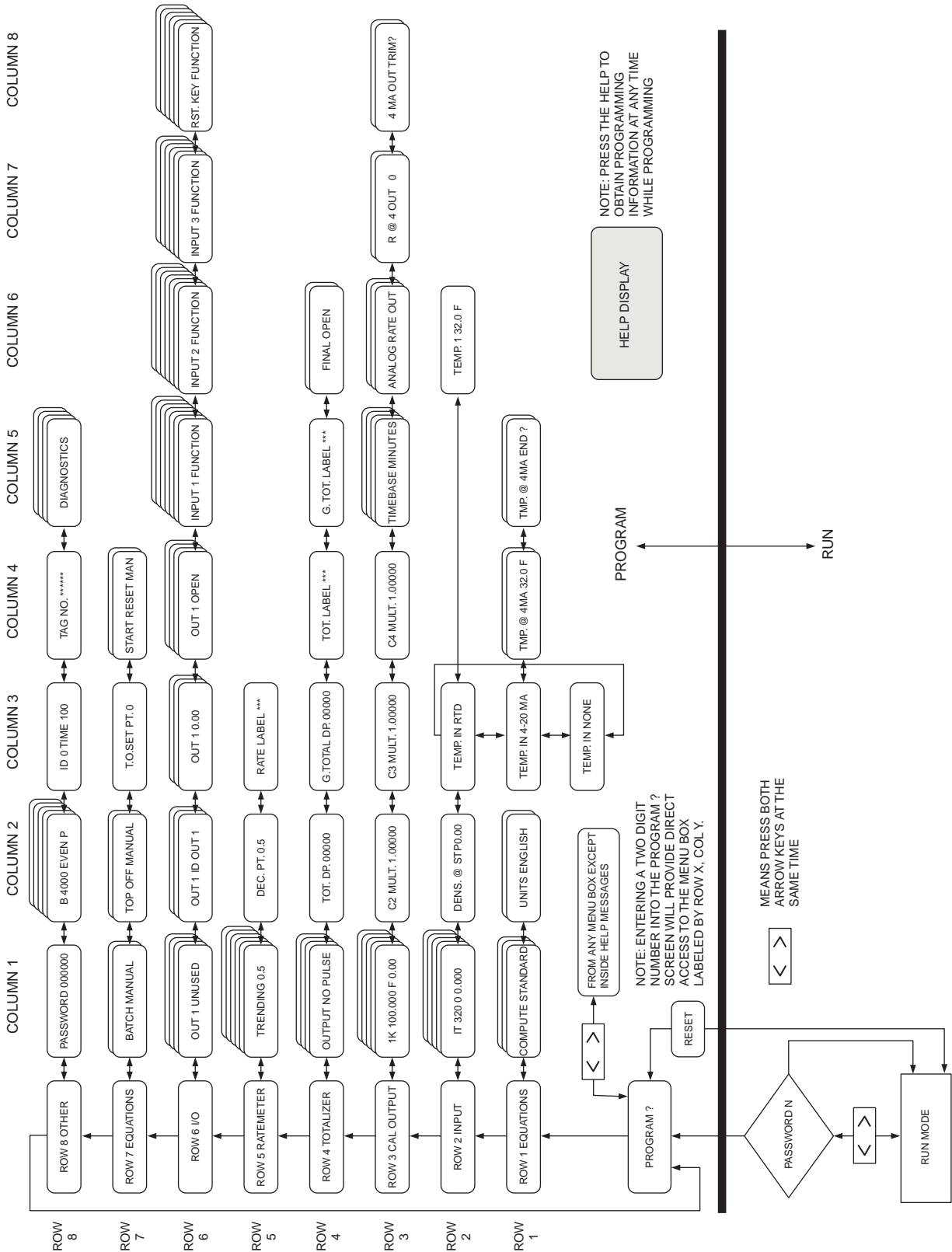

Figure 3. Programming Matrix - Pulse Input Version

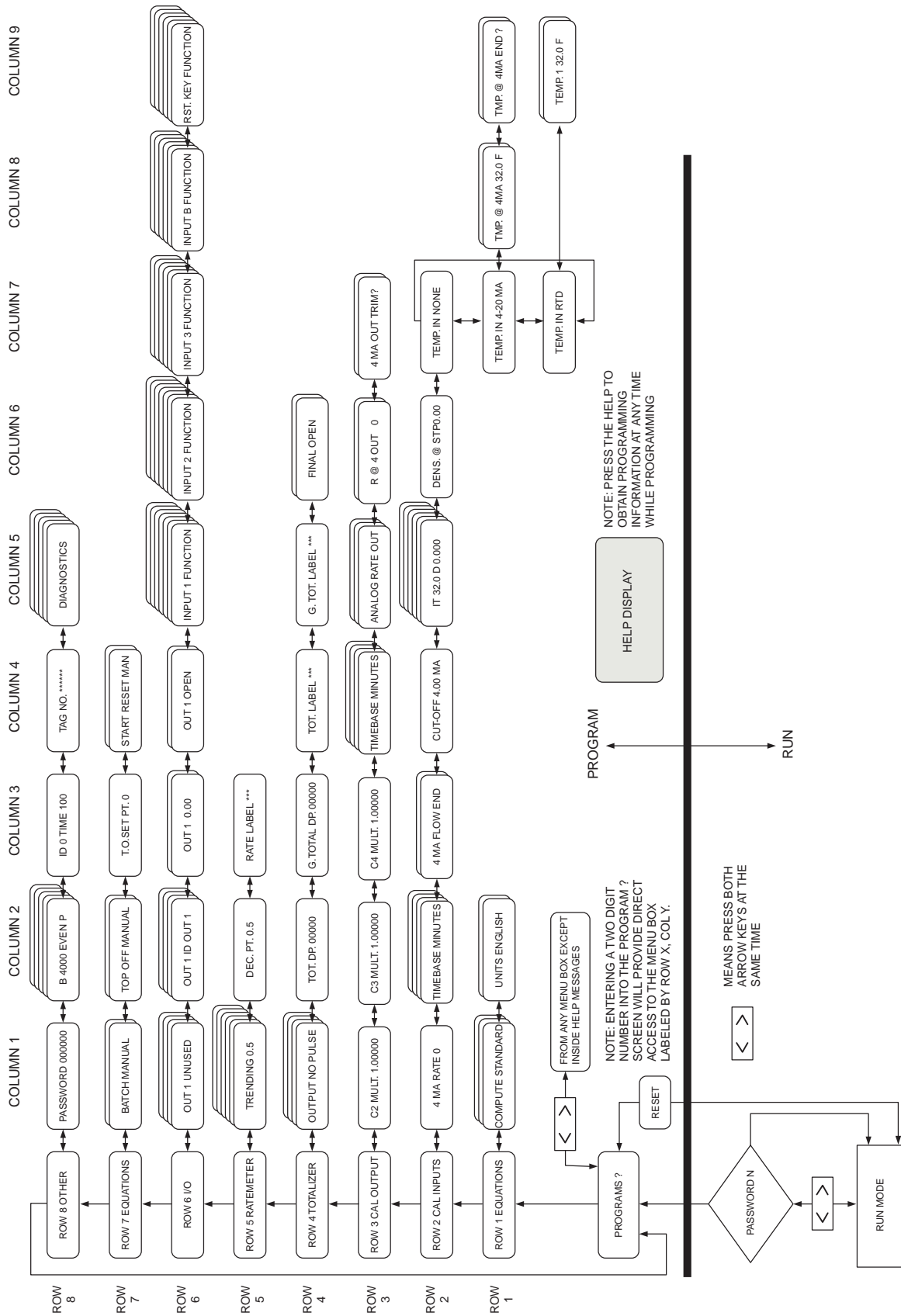
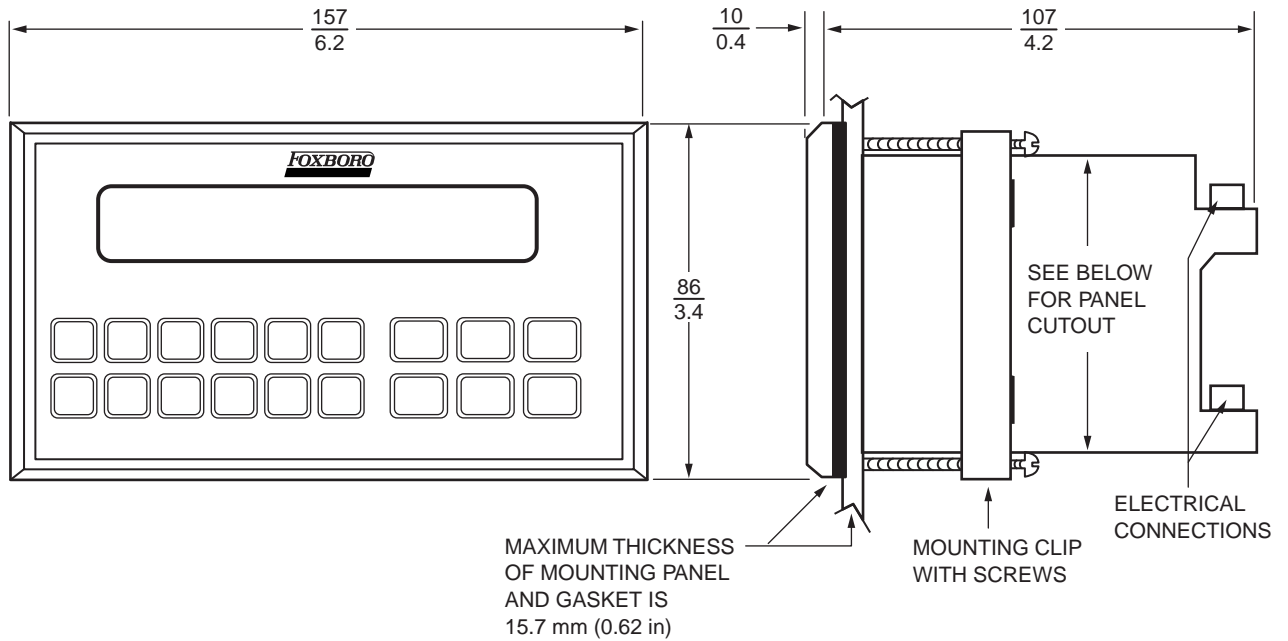

Figure 4. Programming Matrix - Analog Input Version

DIMENSIONS-NOMINAL

**mm
in**

PANEL MOUNTED ENCLOSURE



PANEL CUTOUT AND SPACING

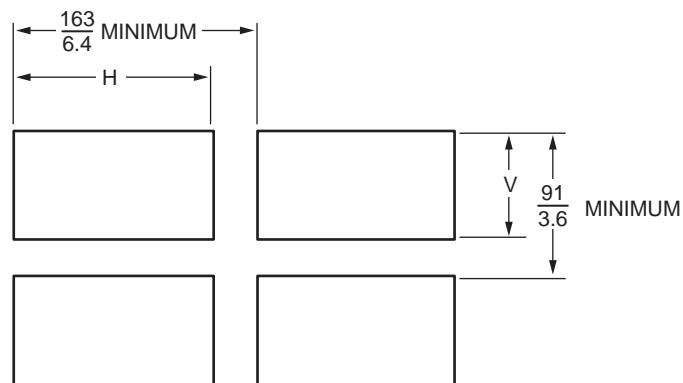

H = 137.7 TO 138.7 mm (5.42 TO 5.46 in)
V = 67.6 TO 68.6 mm (2.66 TO 2.70 in)

DIMENSIONS-NOMINAL (Cont.)

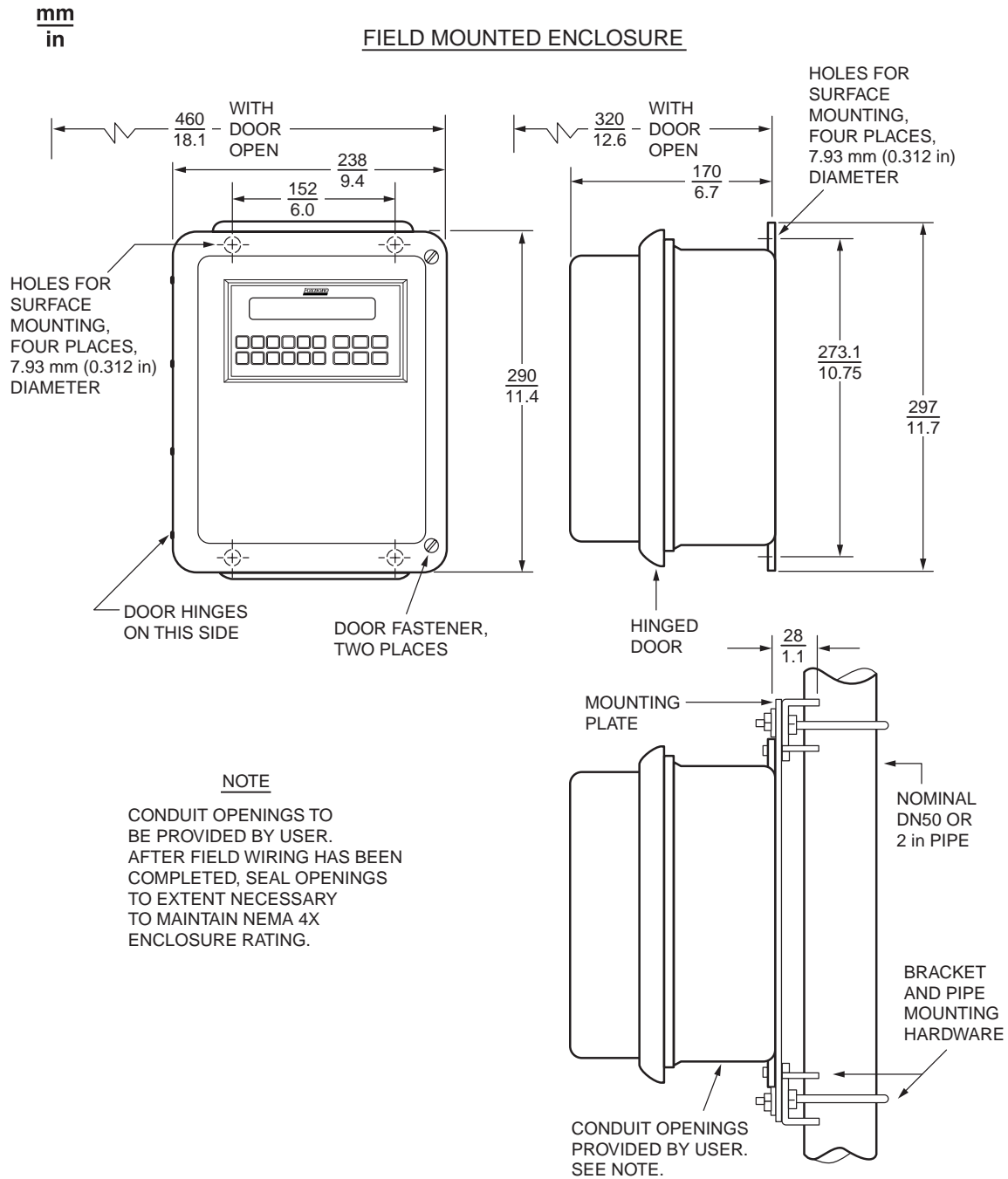

The Foxboro Company
 33 Commercial Street
 Foxboro, MA 02035-2099
 United States of America
<http://www.foxboro.com>
 Inside U.S.: 1-888-FOXBORO
 (1-888-369-2676)
 Outside U.S.: Contact your local
 Foxboro representative.
 Facsimile (508) 549-4492

Foxboro is a registered trademark of The Foxboro Company.
 Siebe is a registered trademark of Siebe, plc.
 Noryl is a trademark of The General Electric Co.

Copyright 1993 by The Foxboro Company
 All rights reserved