

## I/A Series® Multirange Pressure Transmitters

### Model IDP25 for Differential Pressure Measurement w/FoxCom™, HART, or FOUNDATION Fieldbus Communication

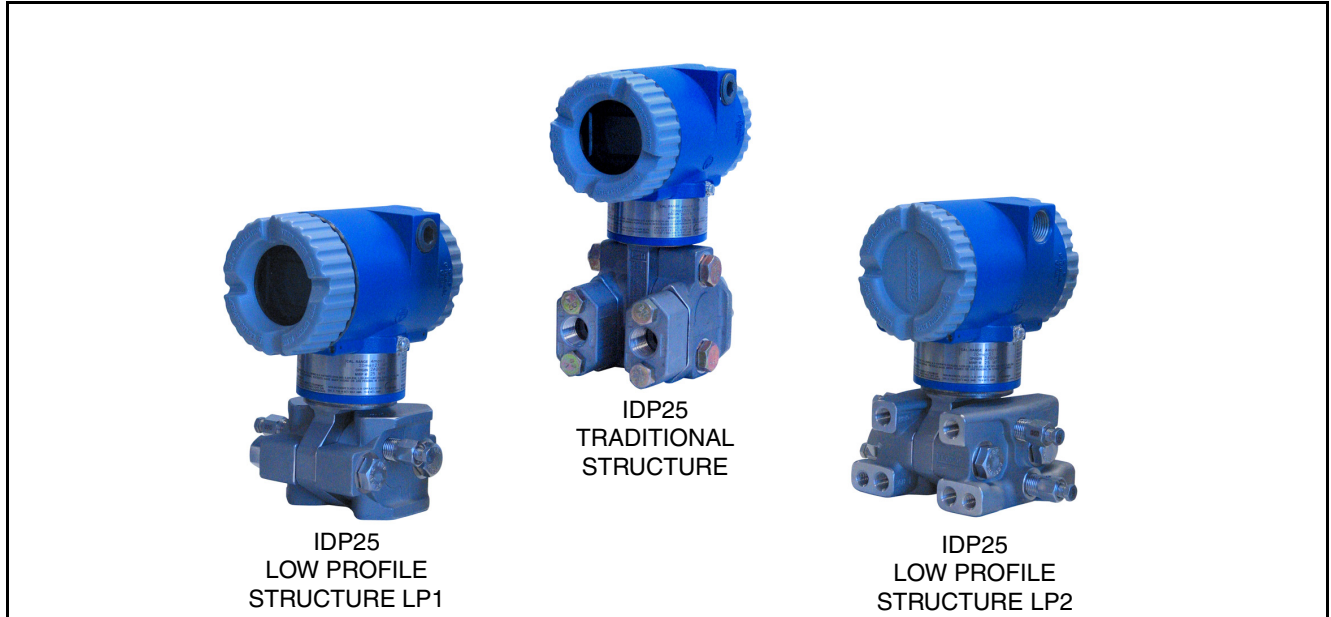

These intelligent, multirange, two-wire d/p Cell® transmitters provide precise, reliable, measurement of differential pressure, providing the measurement range and performance of “two transmitters in one.” They transmit a 4 to 20 mA or digital output signal, as applicable, using FoxCom, HART, or FOUNDATION Fieldbus communication protocol for remote configuration, calibration, and monitoring.

#### FEATURES

- Silicon strain gauge sensors successfully field-proven in many thousands of installations.
- Digital precision, stability, and resolution ensure top measurement performance.
- Multirange transmitters simplify planning, ordering, and spares procurement and stocking.
- Wide measurement spans from 0.12 to 250 kPa (0.5 to 1000 inH<sub>2</sub>O) using only two sensors, each having 400:1 turndown capability.
- Simple, elegant sensor packaging with very few parts achieves exceptionally high reliability.
- A selection of FoxCom, HART, or FOUNDATION Fieldbus Protocols for remote communication.
- Local configuration available with the optional LCD Indicator with on-board pushbuttons.
- Transmitter available with traditional or low profile transmitter structures (see photos above).
- Hastelloy C or Industry Standard 316L ss offered for sensor wetted parts materials.
- Can be provided as a sealed measurement system with numerous configurations of direct connected or capillary connected seals available.
- Durable aluminum or 316 ss housing available; both meet NEMA 4X and IEC IP66.
- Optional mounting bracket sets allow pipe, surface, or manifold mounting of transmitter.
- Complies with applicable EMC and PED European Union Directives; see inside pages.
- FOUNDATION Fieldbus versions are FISCO and FNICO compliant.
- Designed for hazardous area installations. Versions available to meet Agency flameproof and zone requirements.
- Standard 5-year warranty; 17-year optional.

**I/A Series PRESSURE TRANSMITTER FAMILY**

The I/A Series Electronic Pressure Transmitters are a complete family of d/p Cell, gauge, absolute, multirange, multivariable, and premium performance transmitters, as well as transmitters with remote or direct connect seals, all using field-proven silicon strain gauge sensors and common topworks.

**TRUE MULTIRANGE CAPABILITY**

Excellent performance is maintained over a very wide turndown range. The transmitter provides not only the functionality of two transmitters in one, but also provides performance that could previously be attained only by selecting one of several different sensors.

**MULTIRANGE FUNCTIONALITY**

The turndown ratio for span adjustment is 400:1. This means that the IDP25 with its 50 kPa (200 inH<sub>2</sub>O) URL sensor can be set to provide a 4 to 20 mA output for any range between 0 to 0.12 and 0 to 50 kPa (0 to 5 and 0 to 200 inH<sub>2</sub>O). Similarly, the IDP25 transmitter with its 250 kPa (1000 inH<sub>2</sub>O) URL sensor covers any range between 0 to 0.625 and 0 to 250 kPa (0 to 2.5 and 0 to 1000 inH<sub>2</sub>O). Therefore, this means that each sensor covers the ranges normally requiring two separate transmitters.

**MULTIRANGE PERFORMANCE**

Accuracy of  $\pm 0.050\%$  of span is maintained for a span adjustment turndown range of 80:1, and does not exceed  $\pm 0.075\%$  of span until a full 120:1 turndown is reached. Most competitive transmitters have an error greater than  $\pm 0.075\%$  of span when turndowns exceed 10:1 to 20:1.

The IDP25 transmitter can be considered a true multirange transmitter because its performance is maintained over a very wide turndown range, meaning that it performs as well as, or better than, two separate transmitters designed to cover the same turndown range.

**DIGITAL AND 4 TO 20 mA OUTPUT VERSIONS**

The IDP25 Transmitter is offered with FoxCom, HART, or FOUNDATION Fieldbus communication protocols. See paragraphs that follow.

**Digital FoxCom or 4 to 20 mA dc (Configurable) (Version -D Electronics)***FoxCom Digital Output*

Provides Measurement Integration with I/A Series systems, transmission of multiple measurements, and workstation configuration and diagnostics. Also provides digital communications with a PC-based Configurator or optional LCD Indicator with on-board pushbuttons for local configuration and calibration.

*FoxCom 4 to 20 mA Output*

Allows direct analog connection to common receivers while still providing full intelligent transmitter digital communications with a PC-based Configurator, applicable I/A Series system FBMs, or optional LCD Indicator with on-board pushbuttons for local configuration and calibration.

**Digital HART and 4 to 20 mA dc (Version -T Electronics)**

4 to 20 mA with HART communications. Allows direct analog connection to common receivers while still providing full Intelligent Transmitter Digital Communications using a PC-based Configurator, HART Communicator, or optional LCD Indicator with on-board pushbuttons for local configuration and calibration.

Users having HART Communicators for other devices can have them upgraded with Foxboro software to accommodate these transmitters. Also, Foxboro will make use of the HART Foundation library of registered DDs (Device Descriptors), and reload the Communicator if the user desires to keep another supplier's DD along with the Foxboro DD.

**Digital FOUNDATION Fieldbus (Version -F Electronics)**

This all digital, serial, two-way communication system interconnects field devices, such as transmitters, actuators, and controllers. It is a Local Area Network (LAN) with built-in capability to distribute control application across the network. Fieldbus technology consists of a Physical Layer, a Communication Stack, and User Application Blocks. The Communication Stack includes an LAS (Link Access Scheduler), and the User Application Blocks include AI (Analog Input) and PID (proportional, integral, derivative) function blocks. Interoperability of fieldbus devices is achieved using device addresses (IDs) and device descriptors (DDs).

## COMPLIANCE WITH EUROPEAN UNION DIRECTIVES

- Complies with Electromagnetic Compatibility Requirements of European EMC Directive 89/336/EEC by conforming to the following EN and IEC Standards: EN 50081-2, EN 50082-2, and IEC 61000-4-2 through 61000-4-6.
- Complies with NAMUR NE 21 Interference Immunity Requirement (EMC).
- Analog output complies with NAMUR 105 overrange and underrange annunciations.
- Complies with all Applicable European Union Directives ("CE" Logo marked on product).

## HAZARDOUS AREA INSTALLATIONS

Certified for a wide variety of hazardous area requirements.

## FISCO/FNICO COMPLIANT

FOUNDATION Fieldbus Version (Electronic Version -F) certified by ATEX and IECEx for FISCO field device intrinsically safe, and FNICO field device protection n installations. Also certified for intrinsically safe and nonsparking user entity parameters.

## PROCESS CONNECTORS

Removable, gasketed process connectors allow a wide range of selections, including 1/4 NPT, 1/2 NPT, Rc 1/4, Rc 1/2, and weld neck connections.

## SENSOR CORROSION PROTECTION

Choice of 316L ss or highly corrosion resistant Hastelloy C material. See TI 037-75b for process applicability with both 316L ss and Hastelloy C process wetted materials.

## EASE OF INSTALLATION

Rotatable Topworks allows transmitter installation in tight places, allows indicator to be positioned in preferred direction, and eases field retrofit.

Two Conduit Entrances offer a choice of entry positions for ease of installation and self-draining of condensation regardless of mounting position and topworks rotation.

Wiring Guides and Terminations provide ease of wire entry and support, plenty of space to work and store excess wire, and large, rugged screw terminals for easy wire termination.

## OPTIONAL LCD DIGITAL INDICATOR

A two-line digital indicator (Figure 17) with on-board pushbuttons is available to display the measurement with a choice of units. The pushbuttons allow zero and span adjustments, as well as local configuration without the need for a PC-based configurator.

## OPTIONAL MOUNTING BRACKET SETS

In addition to the standard style mounting bracket sets optionally offered with these transmitters, a unique universal style mounting bracket has been developed to allow wide flexibility in transmitter mounting configurations consistent with installation requirements. All mounting bracket sets allow mounting to a surface, pipe, or manifold. Refer to Dimensions - Nominal section.

## UNIQUE PROCESS COVER/CELL BODY DESIGN

Biplanar Construction (Figure 1) maintains the traditional horizontal process connections and vertical mounting by providing a cell body contained between two process covers, while still achieving light weight, small size, and high standard static pressure rating of 25 MPa (3625 psi). This provides easy retrofit of any conventional differential pressure transmitter, and also is easily mounted in the horizontal position with vertical process connections, when required.

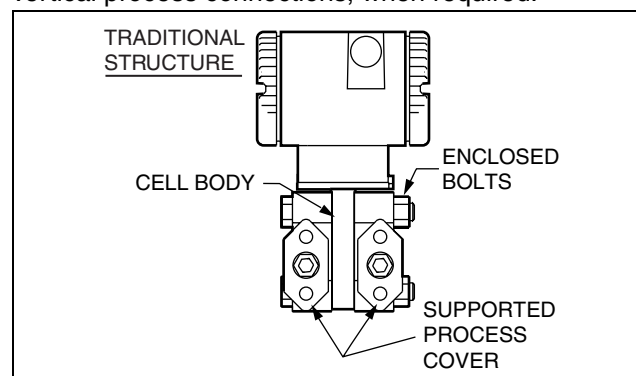

Figure 1. Biplanar Construction Shown with Traditional Horizontal Process Connections

Process Covers (Figure 1) are fully supported by the cell body over their entire height. This prevents bending and results in a highly reliable seal. Also, this provides dimensional stability to the process covers, ensuring that they will always mate properly with 3-valve bypass manifolds.

Process Cover Bolts (Figure 1) are enclosed to minimize corrosion and to minimize early elongation with rapid temperature increases. The design makes it less likely for the transmitter to release process liquid during a fire.

Process Cover Gaskets are ptfе as standard; ptfе provides nearly universal corrosion resistance, and eliminates the need to select and stock various elastomers to assure process compatibility.

Light Weight provides ease of handling, installation, and direct mounting without costly pipe stands.

### TRANSMITTER STRUCTURES

Traditional and low profile structures (LP1 and LP2) are offered to accommodate and to provide flexibility in transmitter installations. See paragraphs below.

#### Traditional Structure

The traditional structure (Figure 2) utilizes the right angle design common to most differential pressure transmitters in use throughout the world. Process connections are oriented 90 degrees from the transmitter centerline.

This traditional structure makes it easy to retrofit any transmitters of similar design.

Sensor cavity venting and draining is provided for both vertical and horizontal transmitter installation, using innovative tangential connections to the sensor cavity (Figures 3 and 4). Optional side vents are offered for sensor cavity venting in the upright position (Figure 5).

An extensive variety of process-wetted materials are available for the process covers on this highly versatile and widely used transmitter.

Refer to the pages that follow for descriptions of low profile structure LP1 and low profile structure LP2.

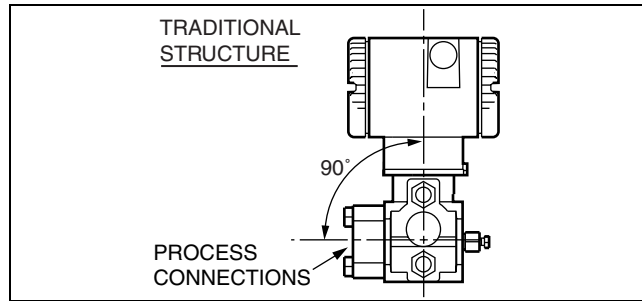

Figure 2. Vertical Mounting Showing Process Connections at 90 degrees

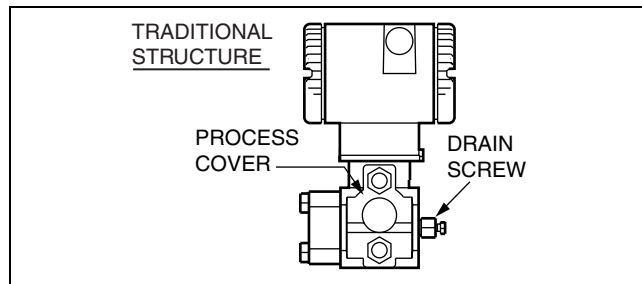

Figure 3. Vertical Mounting - Cavity Draining

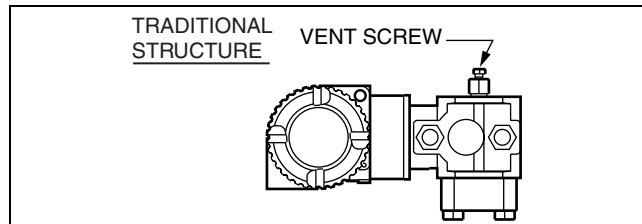

Figure 4. Horizontal Mounting - Cavity Venting, and Self-Draining into Process Line

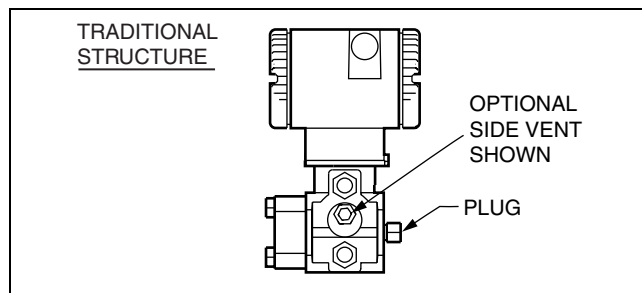

Figure 5. Vertical Mounting - Cavity Venting, and Self-Draining into Process Line

**Low Profile Structures**

The low profile structures utilize an in-line design, placing the process connections in line with the transmitter centerline (Figures 6 and 7). This allows mounting of the transmitter in the upright position with the process connections facing downward, for connection to vertical process piping or for mounting directly to a three- or five-valve manifold.

The low profile structures provide a mounting style similar to that used by competitive Coplanar™ transmitters. This makes it easy to select Foxboro transmitters for both retrofit and new applications where this type of installation is desired.

Transmitters with the low profile structure can be attached directly to existing, installed Coplanar manifolds, such as the Rosemount Model 305RC, or Anderson Greenwood Models MB3, MB5G, and MB5P, by use of an optional adapter plate (see Figure 8). Also, when assembled to the same process piping or manifold as a Coplanar transmitter, one of the electrical conduit connections is located within one inch (plus or minus) of the similar conduit connection on the competitive transmitter, assuring ease of retrofit or conformance with installation design drawings.

All parts making up the low profile versions are identical to the parts in the traditional version except for the process covers and the external shape of the sensor cell body.

For user convenience, two types of low profile structures are offered, type LP1 and LP2. The process covers are the only transmitter parts that differ between structure types LP1 and LP2.

Refer to the sections that follow for further descriptions of low profile structures LP1 and LP2.

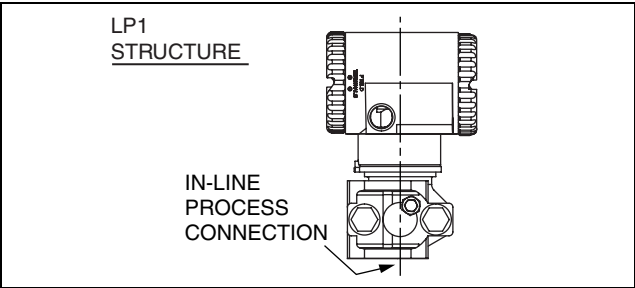

Figure 6. Low Profile Structure - LP1 Shown

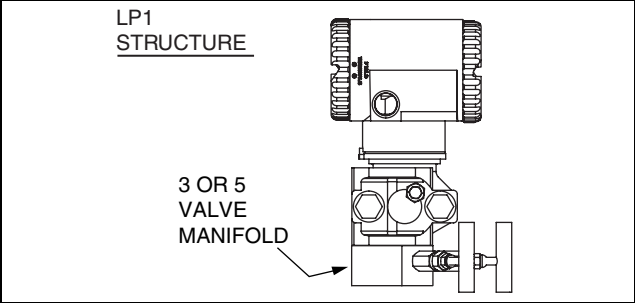

Figure 7. LP1 Shown Directly Mounted to Manifold

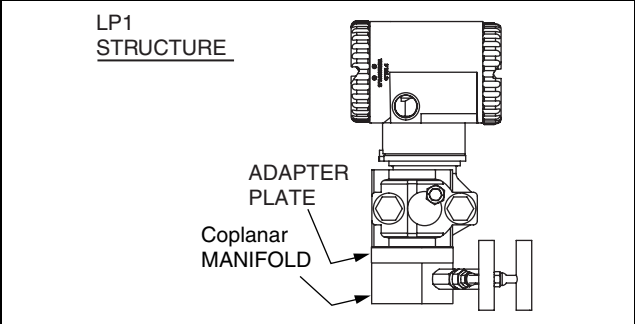

Figure 8. LP1 Shown Mounted to a Coplanar Manifold using an Optional Intermediate Adapter Plate

*Low Profile Structure LP1 – Direct Mount*

Low Profile Structure LP1 is a compact, inexpensive, lightweight design for direct mounting to a separately mounted manifold or process piping. These transmitters are not typically bracket-mounted.

They are supplied as standard with a single vent/drain screw in the side of each process cover. In conjunction with the standard tangential venting and draining design, they are suitable for mounting either vertically (Figure 9) or horizontally, and are suitable for nearly all applications, including liquids, gases, and steam. For horizontal installation, they can simply be “turned over” (rotated 180 degrees - Figures 10 and 11) to orient the high and low pressure sides in the preferred locations. There is no need to unbolt process covers. The topworks housing can also be rotated, as shown, to orient the conduit connections in the desired position.

In the vertical, upright position, they are also self-draining and are ideal for gas flow rate service, when directly mounted to a manifold located above the horizontal pipeline. The vent screw can be omitted for this or other applications, if desired.

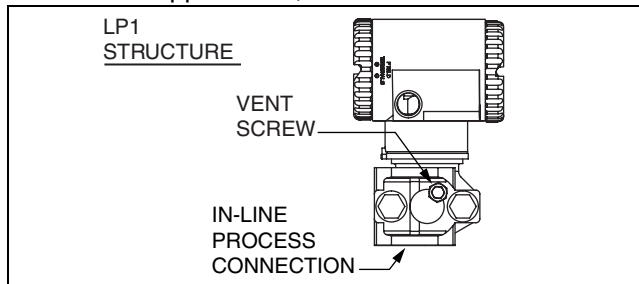

Figure 9. Upright Mounting

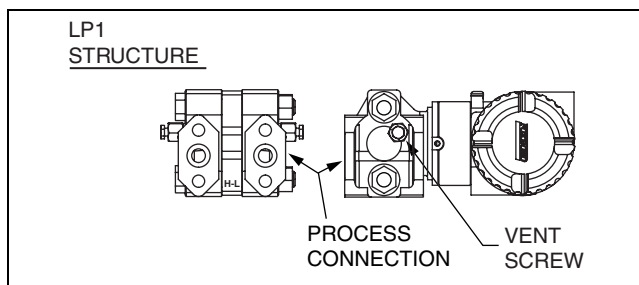

Figure 10. Horizontal Mounting with Vent Screw

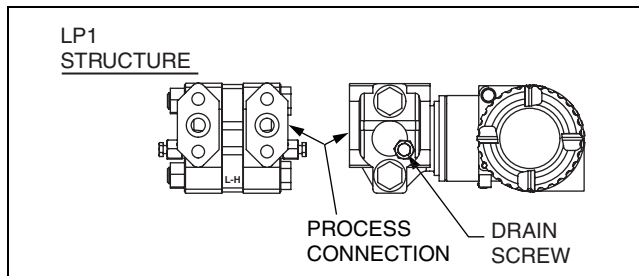

Figure 11. Horizontal Mounting with Drain Screw

*Low Profile Structure LP2 - Bracket or Direct Mount*

Structure LP2 is a universal design for either bracket or direct mounting. Drilled and tapped mounting holes facilitate mounting to either new or existing Foxboro brackets (Options -M1, -M2, and -M3), as well as standard brackets supplied with existing Coplanar transmitters. See Figures 12 and 13.

These transmitters can also be directly mounted to manifolds or process piping and are available with the same optional adapter used with low profile structure LP1 to fit existing Coplanar manifolds (Figure 14).

For extra convenience, they use a full-featured vent and drain design, with separate vent and drain screws positioned in each cover for complete venting or draining directly from the sensor cavity. They are normally recommended for upright, vertical installation.

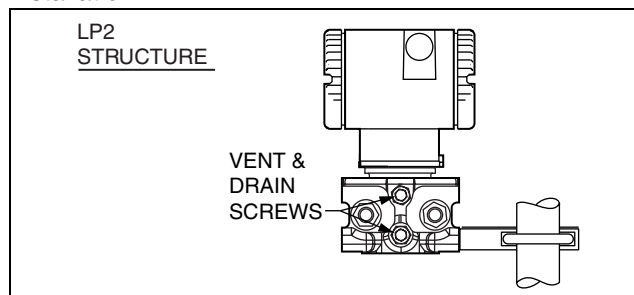

Figure 12. Shown on Foxboro Universal Bracket

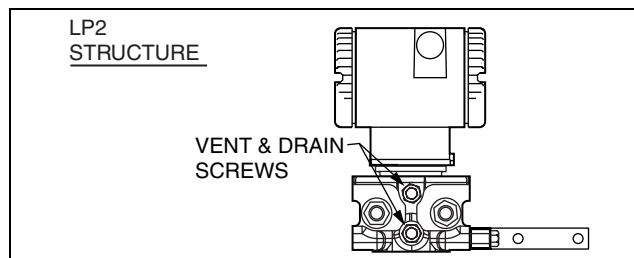

Figure 13. Shown on Coplanar Bracket

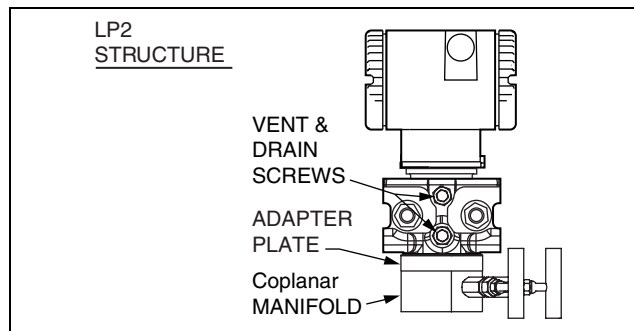

Figure 14. Adapter Mount to Existing Coplanar Manifold

**PRESSURE SEALS**

Pressure seals are used with transmitters having a traditional structure (see Transmitter Structures section above) when it is necessary to keep the transmitter isolated from the process. A sealed system is used for a process fluid that may be corrosive, viscous, subject to temperature extremes, toxic, sanitary, or tend to collect and solidify.

Table 1 lists the various pressure seals that can be used with an IDP25 Transmitter. To order a transmitter with seals, both a Transmitter Model Number and Seal Model Number are required. For a complete listing of pressure seal models and specifications, see PSS 2A-1Z11 A. Also see Figure 15 for typical pressure seal configurations.

Table 1. Pressure Seals Used with IDP25 Transmitters with a Traditional Structure

| Direct Connect Pressure Seal Assemblies                    |  |  |
|--|--|--|
| Seal Model   | Seal Description   | Process Connections  |
| PSFLT  | Flanged, Direct Connect (Flanged Level), Flush or Extended Diaphragm | ANSI Class 150/300/600 flanges and BS/DIN PN 10/40, 10/16, 25/40 flanges                 |
| PSSCT  | Sanitary, Direct Connect (Level Seal), Flush Diaphragm               | Process Connection to Sanitary Piping with 2- or 3-inch Tri-Clamp                        |
| PSSST  | Sanitary, Direct Connect (Level Seal), Extended Diaphragm            | Process Connection to 2-in Mini Spud or 4-in Standard Spud; Tri-Clamp                    |
| Remote Mount, Capillary-Connected Pressure Seal Assemblies |  |  |
| Seal Model   | Seal Description   | Process Connections  |
| PSFPS  | Flanged, Remote Mount, Flush Diaphragm                               | ANSI Class 150/300/600 flanges and BS/DIN PN 10/40 flanges                               |
| PSFES  | Flanged, Remote Mount, Extended Diaphragm                            | ANSI Class 150/300/600 flanges and BS/DIN PN 10/40, 10/16, 25/40 flanges                 |
| PSFAR  | Flanged, Remote Mount, Recessed Diaphragm                            | ANSI Class 150/300/600/1500 flanges  |
| PSTAR  | Threaded, Remote Mount, Recessed Diaphragm                           | 1/4, 1/2, 3/4, 1, or 1 1/2 NPT internal thread   |
| PSISR  | In-Line Saddle Weld, Remote Mount, Recessed Diaphragm                | Lower housing of seal is in-line saddle welded to nominal 3- or 4-inch (and larger) Pipe |
| PSSCR  | Sanitary, Remote Mount, Flush Diaphragm                              | Process Connection secured with a Tri-Clamp to a 2- or 3-inch pipe                       |
| PSSSR  | Sanitary, Remote Mount, Extended Diaphragm                           | Process Connection to 2-in Mini Spud or 4-in Standard Spud; Tri-Clamp                    |



Figure 15. Typical Pressure Seals used with IDP25 Transmitters with a Traditional Structure

**FUNCTIONAL SPECIFICATIONS**

**Span Limits for IDP25 Multirange Differential Pressure Transmitters**

| Span Limit Code | kPa           | inH <sub>2</sub> O | mbar          | psi           | mmHg          |
|-----------------|---------------|--------------------|---------------|---------------|---------------|
| B               | 0.12 and 50   | 0.5 and 200        | 1.2 and 500   | 0.017 and 7.2 | 0.93 and 375  |
| C               | 0.625 and 250 | 2.5 and 1000       | 6.25 and 2500 | 0.09 and 36   | 4.68 and 1870 |

**Range Limits for IDP25 Multirange Differential Pressure Transmitters (a)**

| Span Limit Code | kPa            | inH <sub>2</sub> O | mbar            | psi           | mmHg            |
|-----------------|----------------|--------------------|-----------------|---------------|-----------------|
| B               | -50 and +50    | -200 and +200      | -500 and +500   | -7.2 and +7.2 | -375 and +375   |
| C               | -250 and + 250 | -1000 and +1000    | -2500 and +2500 | -36 and +36   | -1870 and +1870 |

(a) Positive values indicate HI side of sensor at the high pressure, and negative values indicate LO side of sensor at the high pressure.

**Maximum Static and Proof Pressure Ratings for IDP25 Multirange Differential Pressure Transmitters**

| Span Limit Code  | Transmitter Configuration<br>(See Model Code for Description of Options) | Static Pressure Rating (a) |      |                           | Proof Pressure Rating (b) |        |                           |
|------------------|--|----------------------------|------|---------------------------|---------------------------|--------|---------------------------|
|                  |  | MPa                        | psi  | bar or kg/cm <sup>2</sup> | MPa                       | psi    | bar or kg/cm <sup>2</sup> |
| All              | With Option -Y or -D9  | 40                         | 5800 | 400                       | 100                       | 14 500 | 1000                      |
| Span Limit Codes | Standard or with Option -B2, -D3, -D7, -P3, -P7                          | 25                         | 3625 | 250                       | 100                       | 14 500 | 1000                      |
|                  | With Option -B3, -P4, -P8  | 20                         | 2900 | 200                       | 70                        | 11 150 | 700                       |
|                  | With Option -D1  | 16                         | 2320 | 160                       | 64                        | 9280   | 640                       |
|                  | With Option -B1, -D5, -P2, -P6   | 15                         | 2175 | 150                       | 60                        | 8700   | 600                       |
|                  | With Option -D2, -D4, -D6, -D8   | 10                         | 1500 | 100                       | 40                        | 6000   | 400                       |

(a) Static pressure rating of 40 MPa (5800 psi) is optionally available by selecting Option Code -Y. See Model Code section for restrictions with certain options.

(b) Proof pressure ratings meet ANSI/ISA Standard S82.03-1988. Unit may become nonfunctional after application of proof pressure.

**Output Signal and Configuration**

**FOXC0M PROTOCOL (VERSION -D)**

Digital FoxCom or 4 to 20 mA. Configurable using an I/A Series system (with applicable FBMs), a PC-based configurator, or the optional LCD Indicator.

**HART PROTOCOL (VERSION -T)**

4 to 20 mA with HART Communications. When configured for multidrop applications, the mA signal is fixed at 4 mA to provide power to the Transmitter. Configurable using the HART Communicator, a PC-based configurator, or the optional LCD Indicator.

**FOUNDATION FIELDBUS PROTOCOL (VERSION -F)**

This digital, serial, two-way communication system runs at 31.25 kbits/s. The digital output signal is superimposed on the dc power signal on the bus, and controlled by a strict cycle schedule and protocol. Configurable using Host Computer (I/A Series System Workstation or a PC) having a fieldbus interface PWA, or optional LCD Indicator.

**Suppressed Zero and Elevated Zero**

Suppressed or elevated zero ranges acceptable as long as Span and Range Limits are not exceeded.

**Zero and Span Adjustments**

Zero and span adjustments can be initiated from any of the following: I/A Series Workstation (with applicable FBMs), HART Communicator, a PC-based configurator, or the optional LCD Indicator with on-board pushbuttons.

**Zeroing for Nonzero-Based Ranges**

Dual Function Zeroing is provided to allow zeroing with the transmitter open to atmosphere, even when there is a nonzero-based range. This greatly simplifies position effect zeroing on many pressure and level applications. It applies to optional LCD Indicator Pushbuttons and optional External Zero Adjustment.

**Adjustable Damping**

The transmitter response time is normally 0.75 s, or the electronically adjustable setting of 0.00 (none), 0.25, 0.50, 1, 2, 4, 8, 16, or 32 seconds, whichever is greater, for a 90% recovery from an 80% input step as defined in ANSI/ISA S51.1 (for 63.2% recovery, 0.60 s). With FOUNDATION Fieldbus, additional damping is available because damping can be set on both the Transducer and AI blocks.

**FUNCTIONAL SPECIFICATIONS (Cont.)**

**Supply Voltage**

**DIGITAL OUTPUT**

*Version -D Electronics (FoxCom)*

Power supplied through I/A Series System

*Version -T Electronics (HART)*

Bidirectional digital signal superimposed on the 4 to 20 mA current signal.

*Version -F Electronics (FOUNDATION Fieldbus)*

Power supplied through a specific Fieldbus power supply connected to the bus.

**4 TO 20 mA (FoxCom/-D AND HART/-T)**

Minimum voltage shown in Figure 16 is 11.5 V dc.

This can be reduced to 11 V dc by using a plug-in jumper on the terminal block. See Figure 24.

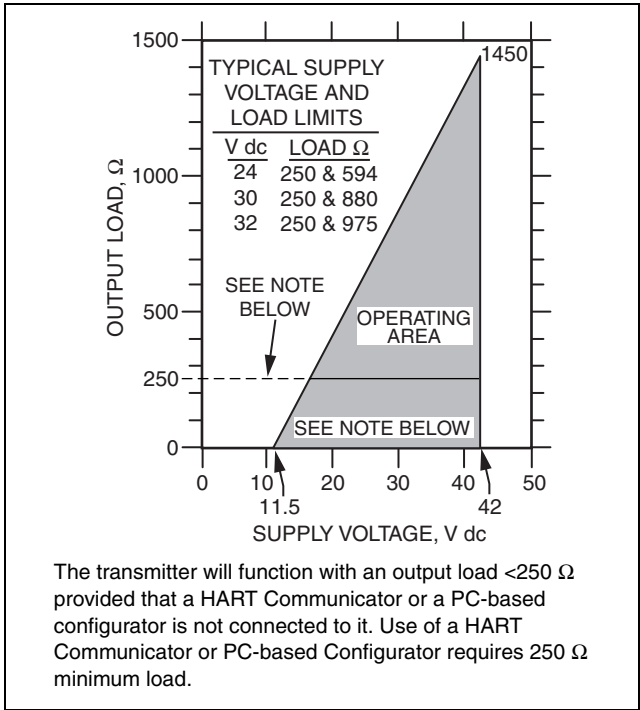

The transmitter will function with an output load <250 Ω provided that a HART Communicator or a PC-based configurator is not connected to it. Use of a HART Communicator or PC-based Configurator requires 250 Ω minimum load.

Figure 16. 4 to 20 mA Output, Supply Voltage vs. Output Load

**Electronics and Sensor Temperatures**

Readable from I/A Series System, HART Communicator, Fieldbus Host System, or PC-based Configurator. Measurement is transmitter temperature at the sensor and the electronics module, not necessarily process temperature.

**Square Root Low Flow Cutoff**

User configurable to provide:

- Cutoff to Zero at Flows < 10% of Maximum Flow (1% of Maximum Differential Pressure).
- Or Active Point-to-Point Line between Zero and 20% of Maximum Flow (4% of Maximum Differential Pressure).
- Flow Cutoff in Engineering Units (Fieldbus Only)

**Write Protect Jumper**

Can be positioned to lock out all configurators from making transmitter database changes. This makes transmitter suitable for Safety Shutdown System Applications that require this feature.

**Field Wiring Reversal**

No transmitter damage.

**Current Outputs for Overrange, Fail, and Offline Conditions - FoxCom and HART Only**

| Parameter      | FoxCom                                  | HART     |
|----------------|---|----------|
| OFFLINE        | User configurable between 4 and 20 mA   |          |
| SENSOR FAILURE | User configurable to Fail LO or Fail HI |          |
| FAIL LO        | 3.60 mA                                 | 3.60 mA  |
| UNDERRANGE     | 3.75 mA                                 | 3.80 mA  |
| OVERRANGE      | 21.00 mA                                | 20.50 mA |
| FAIL HI        | 22.00 mA                                | 21.00 mA |

**Configuration and Calibration Data, and Electronics Upgradeability**

All factory characterization data, and user configuration and calibration data are stored in the sensor. This means that the electronics module can be replaced or changed from one type to another.

A module may be replaced without the need for reconfiguration or recalibration. Although module replacement can affect accuracy up to 0.20% of span, this error can be removed by an mA trim without application of pressure.

Changing module types may require reconfiguration and recalibration, as well as a different terminal block, if applicable, but all factory characterization data is retained.

**FUNCTIONAL SPECIFICATIONS (Cont.)**

**Configuration Capability (See Note below)**

**CALIBRATED RANGE**

- Input range within Span and Range Limits.
- Pressure EGU. See Table 2.

**OUTPUT MEASUREMENT #1 —**

**DIGITAL PRIMARY VARIABLE;  
AND 4 TO 20 mA (FoxCom AND HART ONLY)**

*Mode*

Linear or Square Root

*Units for Linear Mode*

Same as calibrated range;  
or a Custom EGU (FoxCom only)

*Units for Square Root Mode*

% of flow;  
or a Custom EGU (FoxCom only)

**OUTPUT MEASUREMENT #2 —**

**DIGITAL SECONDARY VARIABLE**

*Mode*

Linear or Square Root (Independent of  
Measurement #1)

*Units for Linear Mode*

A common pressure EGU,  
or a custom EGU (FoxCom only)

*Units for Square Root Mode*

% of flow;  
or a Custom EGU (FoxCom only)

*Measurements #1 and #2*

These measurements may be swapped.

**NOTE**

Numerous parameters can be configured and/or displayed, such as electronic damping, failsafe direction, transmitter location, calibration, tag data, etc. See configuration documents for details.

Table 2. Available Units for Calibrated Range

|                    |                        |                        |      |                   |                    |
|--------------------|------------------------|------------------------|------|-------------------|--------------------|
| inH <sub>2</sub> O | cmH <sub>2</sub> O (a) | cmHg (a)               | kPa  | mbar              | kg/cm <sup>2</sup> |
| ftH <sub>2</sub> O | inHg                   | dy/cm <sup>2</sup> (a) | MPa  | bar               | psi                |
| mmH <sub>2</sub> O | mmHg                   | Pa                     | torr | g/cm <sup>2</sup> | atm                |

(a) Available with FoxCom (Version -D) only.

**FoxCom (Version -D) Communications**

**DIGITAL MODE (FIXED CURRENT)**

Digital output signal is updated 10 times per second and carries the pressure measurement, and sensor and electronics temperature measurements. See Table 3 for communication parameters.

**4 TO 20 mA ANALOG MODE**

Analog output is updated a minimum of 30 times per second. A minimum loop load of 250 ohms is required. See Table 3 for communication parameters.

**HART (Version -T) Communications**

**4 TO 20 mA ANALOG MODE**

Analog output signal is updated 30 times per second. A minimum loop load of 250 ohms is required. See Table 3 for communication parameters.

**MULTIDROP MODE (FIXED CURRENT)**

This Mode supports communications with up to 15 transmitters on a single pair of signal/power wires. The output signal is updated 4 times/second. A minimum loop load of 250 ohms is required. See Table 3 for communication parameters and Figure 22 for a typical multidrop block diagram.

**FOUNDATION Fieldbus (Version -F) Digital Communications**

This serial, two-way communication system runs at 31.25 kbits/s. The digital output signal is superimposed on the dc power signal on the bus, and controlled by a strict cycle schedule and protocol. Supply voltage, 9 to 32 V dc, is by a specific Fieldbus power source. Current consumption is 19.5 mA. The maximum number of devices on a non-intrinsically safe bus is 32. For intrinsically safe bus systems, the maximum number is 5. See Table 3 for communication parameters.

Table 3. Communication Parameters - FoxCom, HART, and FOUNDATION Fieldbus

| Parameter                      | FoxCom                                     |                 | HART                                       |                  | Fieldbus   |
|--------------------------------|--|-----------------|--|------------------|--|
|                                | Analog Mode                                | Digital Mode    | Analog Mode                                | Multidrop Mode   | Digital  |
| Remote Configurator            | PC-based Configurator or I/A Series System |                 | HART Communicator or PC-based Configurator |                  | I/A Series System, PC or Fieldbus Certified Host |
| Communication Rate             | 600 baud                                   | 4800 baud       | 1200 baud                                  | 1200 baud        | 31.25 kbits/s                                    |
| Communication Distance (Rated) | 1800 m (6000 ft)                           | 600 m (2000 ft) | 3050 m (10 000 ft)                         | 1525 m (5000 ft) | 1900 m (a) (6235 ft) (a)                         |

(a) The total bus length including all spurs. Maximum spur length is 120 m (395 ft). For hybrid installations, the maximum IS spur length is dependent on the field barrier used. For intrinsically safe bus installations, maximum spur length is 30 m (98 ft).

FUNCTIONAL SPECIFICATIONS (Cont.)

Optional LCD Digital Indicator (Figure 17)

Indicator Provides:

- Two Lines; five numeric characters on top line (four when a minus sign is needed) and seven alphanumeric characters on bottom line.
- Measurement Readout; value on top line and units label on bottom line.
- Configuration and Calibration Prompts.

Two Pushbuttons Provide for:

- Configuration Functions
- Calibration Functions

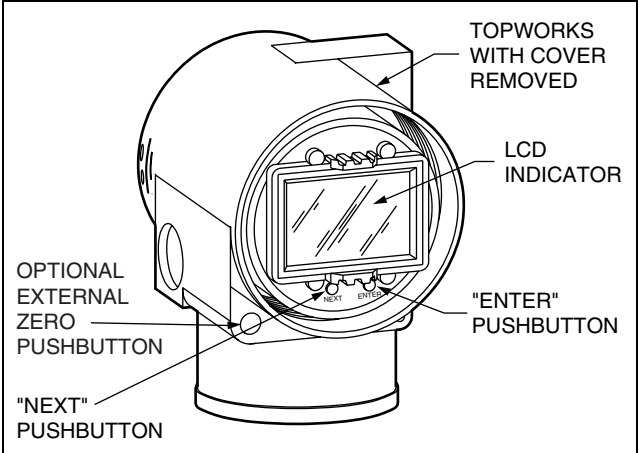

Figure 17. LCD Indicator with Pushbuttons

Optional External Zero Adjustment

An external pushbutton mechanism is isolated from the electronics compartment and magnetically activates an internal reed switch through the housing. This eliminates a potential leak path for moisture or contaminants to get into the electronics compartment. This external zero adjustment can be disabled by a configuration selection. See Figure 17.

Optional Custom Configuration (Option -C2)

For the transmitter to be custom configured by the factory, the user must fill out a data form. If this option is not selected, a standard default configuration will be provided. Refer to the example in Table 4.

Table 4. Option -C2 Configuration Example

| Parameter     | Standard (Default) Configuration | Example of Custom Configuration Option -C2 |
|---------------|----------------------------------|--|
| Measurement 1 | Linear                           | Square Root                                |
| Device Name   | DevNam                           | FT103A                                     |
| External Zero | Enabled                          | Disabled                                   |
| EGU           | %                                | inH <sub>2</sub> O                         |
| Damping       | None                             | 0.5 s                                      |

**FUNCTIONAL BLOCK DIAGRAMS**

Refer to Figures 18 to 23 for typical FoxCom, HART, and FOUNDATION Fieldbus installation topologies

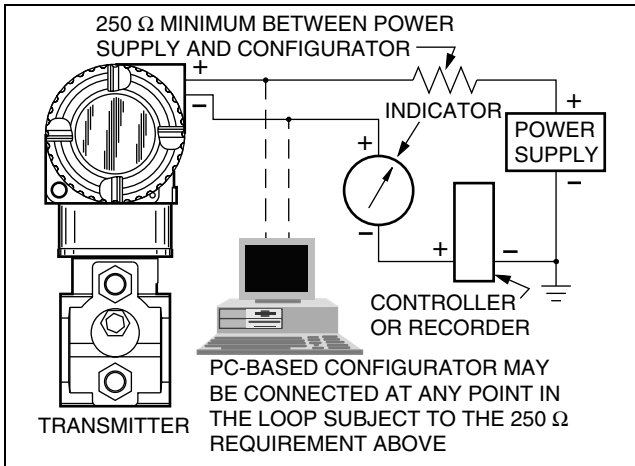

Figure 18. FoxCom 4 to 20 mA Topology

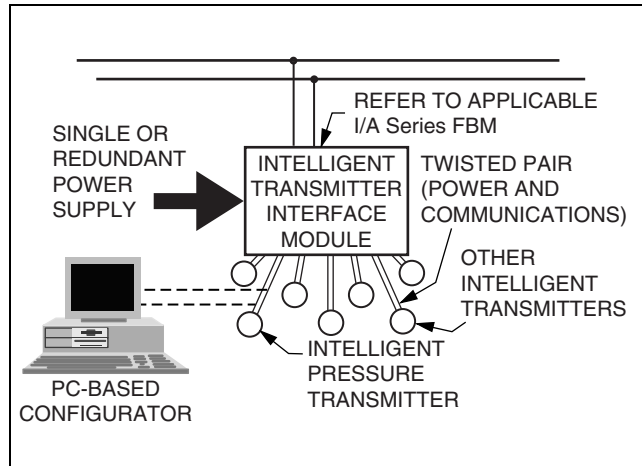

Figure 21. FoxCom Digital Topology

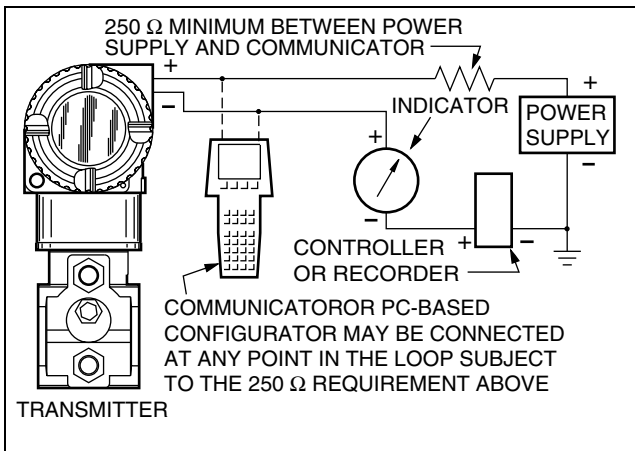

Figure 19. HART 4 to 20 mA Topology

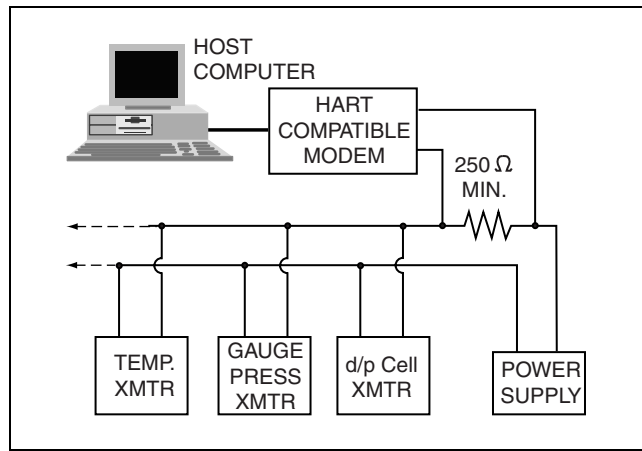

Figure 22. HART Multidrop Topology

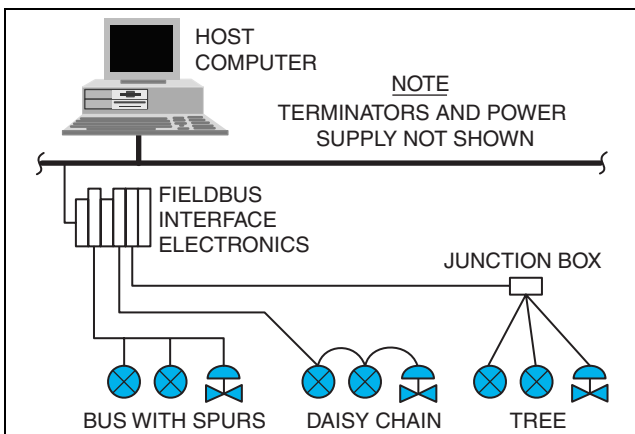

Figure 20. Fieldbus Miscellaneous Topologies

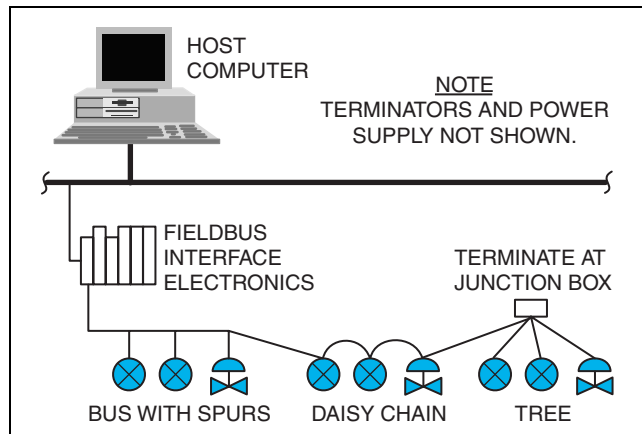

Figure 23. Fieldbus with Mixed Topologies

## OPERATING, STORAGE, AND TRANSPORTATION CONDITIONS

| Influence  | Reference Operating Conditions                       | Normal Operating Conditions (a)  | Operative Limits (a)   | Storage and Transportation Limits  |
|--|--|--|--|--|
| Process Connection Temperature<br>• w/Silicone Fill Fluid<br><br>• w/Fluorinert Fill Fluid | • 24 ±2°C<br>(75 ±3°F)<br><br>• 24 ±2°C<br>(75 ±3°F) | • -29 to + 82°C<br>(-20 to +180°F)<br><br>• -29 to + 82°C<br>(-20 to +180°F)   | • -46 and +121°C (b)<br>(-50 and +250°F) (b)<br><br>• -29 and +121°C<br>(-20 and +250°F)   | • Not Applicable<br><br>• Not Applicable                                       |
| Electronics Temperature<br><br>• with LCD Indicator<br>(Note c)                            | • 24 ±2°C<br>(75 ±3°F)<br><br>• 24 ±2°C<br>(75 ±3°F) | • -29 to + 82 °C(j)<br>(-20 to +180 °F)(j)<br><br>• -20 to + 82 °C(j)<br>(-4 to +180 °F)(j)  | • -40 and +85°C(j)<br>(-40 and +185°F)(j)<br><br>• -29 and +85°C(j)<br>(-20 and +185°F)(j) | • -54 and +85°C<br>(-65 and +185°F)<br><br>• -54 and +85°C<br>(-65 and +185°F) |
| Relative Humidity (Note d)   | 50 ±10%  | 0 to 100%  | 0 and 100%   | 0 and 100%<br>Noncondensing  |
| Supply Voltage – mA Output<br>FoxCom and HART  | 30 ±0.5 V dc   | 11.5 to 42 V dc<br>(Note e)  | 11.5 and 42 V dc<br>(Note e)   | Not Applicable   |
| Output Load – mA Output<br>FoxCom and HART   | 650 Ω  | 0 to 1450 Ω<br>(Note f)  | 0 and 1450 Ω<br>(Note f)   | Not Applicable   |
| Supply Voltage<br>FOUNDATION Fieldbus  | 30 ±0.5 V dc   | 9 to 32 V dc<br>(Note g)   | 9 and 32 V dc<br>(Note g)  | Not Applicable   |
| Vibration  | 1 m/s <sup>2</sup><br>(0.1 “g”)                      | 6.3 mm (0.25 in) Double Amplitude:<br>from 5 to 15 Hz with Aluminum Housing<br>from 5 to 9 Hz with 316 ss Housing<br>-----<br>0 to 30 m/s <sup>2</sup> (0 to 3 “g”) from 15 to 500 Hz<br>with Aluminum Housing;<br>0 to 10 m/s <sup>2</sup> (0 to 1 “g”) from 9 to 500 Hz<br>with 316 ss Housing | 11 m/s <sup>2</sup><br>(1.1 “g”)<br>from 2.5 to 5 Hz<br>(in Shipping<br>Package)           |  |
| Mounting Position  | Upright or<br>Horizontal (h)                         | Upright or Horizontal<br>(h)   | No Limit   | Not Applicable   |

(a) When DIN Construction Options -D2, -D4, -D6, and -D8 are used, the temperature limits are reduced to 0 and 60°C (32 and 140°F).

(b) Selection of Option -J extends the low temperature operative limit of transmitters with silicone filled sensors down to -50°C (-58°F).

(c) Although the LCD will not be damaged at any temperature within the “Storage and Transportation Limits”, updates will be slowed and readability decreased at temperatures outside the “Normal Operating Conditions”.

(d) With topworks cover on and conduit entrances sealed.

(e) 11.5 V dc can be reduced to 11 V dc by using a plug-in shorting bar (not applicable to fieldbus versions).

(f) With FoxCom and with HART, 250 Ω minimum load required for proper communication.

(g) Power supplied by a specific Fieldbus power supply.

(h) Sensor process wetted diaphragms in a vertical plane.

(j) Refer to the Electrical Safety Specifications section for a restriction in ambient temperature with certain electrical certifications.

**PERFORMANCE SPECIFICATIONS**

Zero-Based Calibrations; Stainless Steel Sensor w/Silicone Fluid; Under Reference Operating Conditions unless otherwise Specified; URL = Upper Range Limit and Span = Calibrated Span

**Accuracy (Linear Output) - Table 1 (a)**

| Accuracy, % of Span (b) (c) |                         |
|-----------------------------|-------------------------|
| Spans ≥1.25% URL            | Spans <1.25% URL        |
| ±0.050%                     | ±[0.000625 (URL/Span)]% |

- (a) Accuracy includes Linearity, Hysteresis, and Repeatability.
- (b) Applies to HART (4 to 20 mA or digital), FOUNDATION fieldbus, and FoxCom digital.
- (c) Accuracy is ±0.075% of span for turndowns up to 120:1 for the FoxCom 4 to 20 mA signal.

**Accuracy (Square Root Output) (a)**

| Operating Point % of Flow Rate Span | Accuracy % of Flow Rate Span  |
|-------------------------------------|---|
| 50% and Greater                     | Accuracy % from Table 1   |
| Less than 50% (to cutoff)           | $\frac{(Accuracy \% \text{ from Table 1})(50)}{\text{Operating Point in \% of Flow Rate Span}}$ |

- (a) Accuracy includes Linearity, Hysteresis, and Repeatability.

**Stability**

Long term drift is ±0.15% of URL for 10 years (reference conditions).

**Calibration Frequency**

The calibration frequency is five years. The five years is derived using the values of allowable error (% span), TPE (% span), performance margin (% span), and stability (% span/month); where:

$$\text{Calibration Frequency} = \frac{\text{Performance Margin}}{\text{Stability}} = \text{Months}$$

**Power-up Time**

Less than 5 seconds for output to reach first valid measurement.

**RFI Effect**

The output error is less than 0.1% of span for radio frequencies in the range of 27 to 1000 MHz and field intensity of 30 V/m when the transmitter is properly installed with shielded cable in conduit and earthing (grounding), and housing covers are in place. (Per IEC Std. 61000-4-3.)

**Vibration Effect**

Total effect is ±0.2% of URL per “g” for vibrations in the frequency range of 5 to 500 Hz; with double amplitudes of 6.3 mm (0.25 in) in the range of 5 to 15 Hz, or accelerations of 3 “g” in the range of 15 to 500 Hz, whichever is smaller, for transmitter with aluminum housing; and with double amplitudes of 6.3 mm (0.25 in) in the range of 5 to 9 Hz, or accelerations of 1 “g” in the range of 9 to 500 Hz, whichever is smaller, for transmitter with 316 ss housing.

**Supply Voltage Effect**

The output changes less than 0.005% of span for each 1 V change within the specified supply voltage requirements.

**Position Effect**

Transmitter may be mounted in any position. Any zero effect caused by mounting position can be eliminated by rezeroing. There is no span effect.

**Static Pressure Effect**

The zero and span shift for a 7 MPa, 1000 psi, change in static pressure is:

ZERO SHIFT

| Span Code | Zero Shift-Static Pressure Effect |
|-----------|-----------------------------------|
| B         | ±0.07% of URL                     |
| C         | ±0.02% of URL                     |

SPAN SHIFT

±0.1% of Reading

**Ambient Temperature Effect**

Total effect for a 28°C (50°F) change within Normal Operating Condition limits is:

±(0.03% URL + 0.06% Span)

**NOTE**

Temperature effects due to pressure seal(s) are additive.

**Switching and Indirect Lightning Transients**

The transmitter can withstand a transient surge up to 2000 V common mode or 1000 V normal mode without permanent damage. The output shift is less than 1.0%. (Per ANSI/IEEE C62.41-1980 and IEC Std. 61000-4-5.)

PHYSICAL SPECIFICATIONS

Environmental Protection

Transmitter is dusttight and weatherproof per IEC IP66 and provides the environmental and corrosion resistant protection of NEMA Type 4X.

Process Cover and Process Connector Gaskets

Glass filled ptfe (Chemloy)

Process Cover Bolts and Nuts

ASTM™ A193, Grade B7 high strength alloy steel for bolts, and ASTM A194 Grade 2H high strength alloy steel for nuts are standard. Options include NACE Class B7M bolting, 17-4 ss bolting, and 316 ss bolting.

Sensor Material (Process Wetted)

Industry Standard 316 L ss and Hastelloy C. Refer to TI 37-75b regarding the corrosion resistance of 316L ss and Hastelloy C when used with different processes.

Process Cover and Connector Material (Process Wetted)

316 ss or Hastelloy C

Sensor Fill Fluids

Silicone Oil or Fluorinert (FC-43)

Mounting Position

The transmitter may be mounted in any orientation.

Electronics Housing and Housing Covers

Housing has two compartments to separate the electronics from the field connections. The housing and covers are made from low copper, die-cast aluminum alloy with an epoxy finish, or from 316 ss. Buna-N O-ring seals are used to seal the threaded housing covers, housing neck, and terminal block.

Electronics Module

Printed wiring assemblies are conformally coated for moisture and dust protection.

Electrical Connections

Field wires enter through 1/2 NPT, PG 13.5, or M20 threaded entrances on either side of the electronics housing. Wires terminate under screw terminals and washers on terminal block in the field terminal compartment (Figure 24). Unused entrance is plugged to insure moisture and RFI/EMI protection.

Approximate Mass

- 3.5 kg (7.8 lb) – Aluminum Housing; and without Process Connectors
- 4.2 kg (9.2 lb) – Aluminum Housing; and with Process Connectors
- Add 1.1 kg (2.4 lb) – with 316 ss Housing
- Add 0.2 kg (0.4 lb) – with LCD Indicator Option
- Add pressure seal(s) mass.

Dimensions

See Dimensions - Nominal section and DP 020-446.

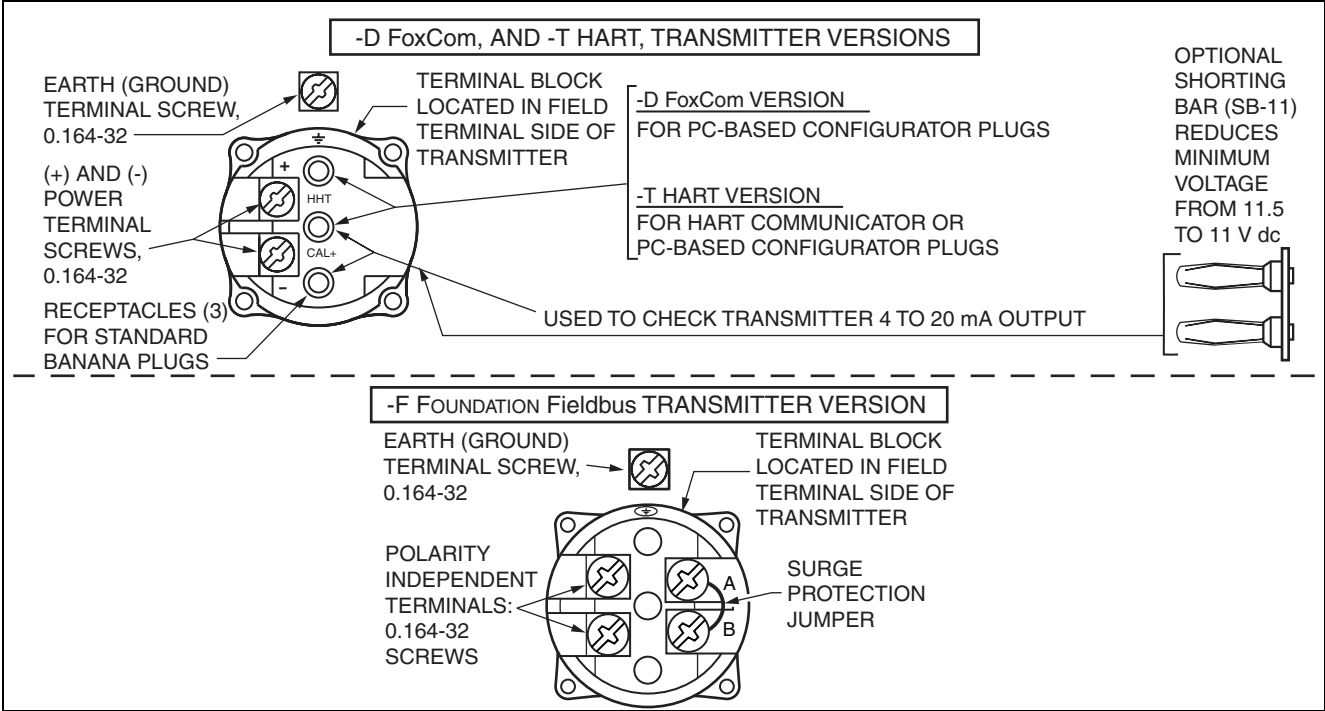

Figure 24. Field Terminals Compartment for FoxCom, HART, and Fieldbus

**ELECTRICAL SAFETY SPECIFICATIONS**

1. Transmitter has been designed to meet the Electrical Safety Specifications listed in the tables that follow. Contact Invensys Foxboro for information or status of testing laboratory approvals or certifications.
2. With Electrical Safety Design Code M, the user must permanently mark (check off on rectangular box on data plate) one type of protection only (ia and ib, d, or n). This mark cannot be changed once it is applied.

**Electronic Version -D (FoxCom)**

| <b>Testing Laboratory, Types of Protection, and Area Classification</b>  | <b>Application Conditions</b>  | <b>Elec. Safety Design Code</b> |
|--|--|---------------------------------|
| <b>ATEX</b> intrinsically safe; II 1 GD, EEx ia IIC, Zone 0, or II 1/2 GD EEx ib IIC, Zone 0/Zone 1.   | Temperature Class T4 at 80°C, T5 at 40°C, and T6 at 40°C maximum ambient.              | E                               |
| <b>ATEX</b> flameproof; II 2 GD, EEx d IIC, Zone 1.  | Temperature Class T6, 85°C; Ta = -40 to +75°C.   | D                               |
| <b>ATEX</b> protection n; II 3 GD, EEx nL IIC, Zone 2.   | Temperature Class T4 at 80°C, T5 at 70°C, and T6 at 40°C maximum ambient.              | N                               |
| <b>ATEX</b> multiple certifications, ia & ib, d, and n. Refer to Codes E and N for details.  | Applies to Codes D, E, and N. Note 2.  | M                               |
| <b>CSA</b> intrinsically safe for Class I, Division 1, Groups A, B, C, and D, Class II, Division 1, Groups E, F, and G, and Class III, Division 1.                 | Connect per MI 020-427. Temperature Class T6 at 40°C, and T4A at 85°C maximum ambient. | C                               |
| <b>CSA</b> explosionproof for Class I, Division 1, Groups B, C, and D; dust-ignitionproof for Class II, Division 1, Groups E, F, and G; and Class III, Division 1. | Maximum Ambient Temperature 85°C.  | C                               |
| <b>CSA</b> for Class I, Division 2, Groups A, B, C, and D; Class II, Division 2, Groups F and G; Class III, Division 2.  | Temperature Class T6 at 40°C and T4A at 85°C maximum ambient.                          | C                               |
| <b>CSA</b> field device zone certified flameproof Ex d IIC. Also, all certifications of Code C above.  | Maximum Ambient Temperature 85°C.  | B                               |
| <b>FM</b> intrinsically safe for Class I, Division 1, Groups A, B, C, and D; Class II, Division 1, Groups E, F, and G; and Class III, Division 1.                  | Connect per MI 020-427. Temperature Class T4A at 40°C and T4 at 85°C maximum ambient.  | F                               |
| <b>FM</b> explosionproof for Class I, Division 1, Groups B, C, and D; dust-ignitionproof for Class II, Division 1, Groups E, F, and G; and Class III, Division 1.  | Temperature Class T6 at 80°C and T5 at 85°C maximum ambient.                           | F                               |
| <b>FM</b> nonincendive Class I, Division 2, Groups A, B, C, and D; Class II, Division 2, Groups F and G; and Class III, Division 2.                                | Temperature Class T4A at 40°C and T4 at 85°C maximum ambient.                          | F                               |
| <b>FM</b> field device zone certified flameproof AEx d IIC. Also, all certifications of Code F above.  | Temperature Class T6 at 80°C, and T5 at 85°C maximum ambient.                          | G                               |
| <b>IECEx</b> flameproof, Ex d IIC.   | T6, Ta = 80°C; T5, Ta = 85°C; Ambient Temperature -20 to +85°C.                        | V                               |

**ELECTRICAL SAFETY SPECIFICATIONS (Cont.)****Electronic Version -T (HART)**

| <b>Testing Laboratory, Types of Protection, and Area Classification</b>  | <b>Application Conditions</b>   | <b>Elec. Safety Design Code</b> |
|--|---|---------------------------------|
| <b>ATEX</b> intrinsically safe; II 1 GD, EEx ia IIC, Zone 0, or II 1/2 GD EEx ib IIC, Zone 0/Zone 1.   | Temperature Class T4 at 80°C, T5 at 40°C, and T6 at 40°C maximum ambient.               | E                               |
| <b>ATEX</b> flameproof; II 2 GD, EEx d IIC, Zone 1.  | Temperature Class T6, 85°C; Ta = -40 to +75°C.  | D                               |
| <b>ATEX</b> protection n; II 3 GD, EEx nL IIC, Zone 2.   | Temperature Class T4 at 80°C, T5 at 70°C, and T6 at 40°C maximum ambient.               | N                               |
| <b>ATEX</b> multiple certifications, ia & ib, d, and n. Refer to Codes E and N for details.  | Applies to Codes D, E, and N. Note 2.   | M                               |
| <b>CSA</b> intrinsically safe for Class I, Division 1, Groups A, B, C, and D, Class II, Division 1, Groups E, F, and G, and Class III, Division 1.                 | Connect per MI 020-427. Temperature Class T4A at 40°C, and T3C at 85°C maximum ambient. | C                               |
| <b>CSA</b> zone certified intrinsically safe Ex ia IIC, and energy limited Ex nA II.   | Temperature Class T4 at 40°C, and T3 at 85°C maximum ambient.                           | C                               |
| <b>CSA</b> explosionproof for Class I, Division 1, Groups B, C, and D; dust-ignitionproof for Class II, Division 1, Groups E, F, and G; and Class III, Division 1. | Maximum Ambient Temperature 85°C.   | C                               |
| <b>CSA</b> for Class I, Division 2, Groups A, B, C, and D; Class II, Division 2, Groups F and G; Class III, Division 2.  | Temperature Class T4A at 40°C and T3C at 85°C maximum ambient.                          | C                               |
| <b>CSA</b> field device zone certified flameproof Ex d IIC. Also, all certifications of Code C above.  | Maximum Ambient Temperature 85°C.   | B                               |
| <b>FM</b> intrinsically safe for Class I, Division 1, Groups A, B, C, and D; Class II, Division 1, Groups E, F, and G; and Class III, Division 1.                  | Connect per MI 020-427. Temperature Class T4A at 40°C and T4 at 85°C maximum ambient.   | F                               |
| <b>FM</b> zone certified intrinsically safe AEx ia IIC.  | Temperature Class T4 at 85°C maximum ambient.   | F                               |
| <b>FM</b> explosionproof for Class I, Division 1, Groups B, C, and D; dust-ignitionproof for Class II, Division 1, Groups E, F, and G; and Class III, Division 1.  | Temperature Class T6 at 80°C and T5 at 85°C maximum ambient.                            | F                               |
| <b>FM</b> nonincendive Class I, Division 2, Groups A, B, C, and D; Class II, Division 2, Groups F and G; and Class III, Division 2.                                | Temperature Class T4A at 40°C and T4 at 85°C maximum ambient.                           | F                               |
| <b>FM</b> field device zone certified flameproof AEx d IIC. Also, all certifications of Code F above.  | Temperature Class T6 at 75°C maximum ambient.   | G                               |
| <b>IECEx</b> flameproof, Ex d IIC.   | T6, Ta = 80°C; T5, Ta = 85°C; Ambient Temperature -20 to +85°C.                         | V                               |
| <b>SAA</b> intrinsically safe, Ex ia IIC, Gas Group IIC, Zone 0.   | Temperature Class T4 at 85°C maximum ambient.   | H                               |
| <b>SAA</b> nonincendive, Ex n IIC, Gas Group IIC, Zone 2.  | Temperature Class T6.   | K                               |

## ELECTRICAL SAFETY SPECIFICATIONS (Cont.)

## Electronic Version -F (FOUNDATION Fieldbus)

| Testing Laboratory, Types of Protection, and Area Classification  | Application Conditions   | Elec. Safety Design Code |
|---|--|--------------------------|
| <b>ATEX</b> FISCO field device intrinsically safe; II 1 G, EEx ia IIC, Zone 0.  | Temperature Class T4, Ta = -40 to +80°C.                           | E                        |
| <b>ATEX</b> flameproof; II 2 GD, EEx d IIC, Zone 1.   | Temperature Class T6, 85°C; Ta = -40 to +80°C.                     | D                        |
| <b>ATEX</b> FNICO field device protection n: II 3 G, EEx nL IIC, Zone 2.  | Temperature Class T4, Ta = -40 to +80°C.                           | N                        |
| <b>CSA</b> FISCO field device intrinsically safe for Class I, Division 1, Groups A, B, C, and D; Class II, Division 1, Groups E, F, and G; and Class III, Division 1.<br>Also, Zone certified intrinsically safe Ex ia IIC. | Temperature Class T4A at 40°C and T3C at 85°C maximum ambient.     | C                        |
| <b>CSA</b> FNICO field device nonincendive for Class I, Division 2, Groups A, B, C, and D; Suitable for Class II, Division 2, Groups F and G; and Class III, Division 2.  | Temperature Class T4A at 40°C and T3C at 85°C maximum ambient.     | C                        |
| <b>CSA</b> explosionproof for Class I, Division 1, Groups B, C, and D; dust-ignitionproof for Class II, Division 1, Groups E, F, and G; and Class III, Division 1.  | Maximum Ambient Temperature 85°C.                                  | C                        |
| <b>CSA</b> field device zone certified flameproof Ex d IIC. Also, all certifications of Code C above.   | Maximum Ambient Temperature 85°C.                                  | B                        |
| <b>FM</b> FISCO field device intrinsically safe for Class I, Division 1, Groups A, B, C, and D; Class II, Division 1, Groups E, F, and G; and Class III, Division 1.<br>Also, Zone certified intrinsically safe AEx ia IIC. | Temperature Class T4A at 40°C and T4 at 85°C maximum ambient.      | F                        |
| <b>FM</b> FNICO field device nonincendive for Class I, Division 2, Groups A, B, C, and D; Suitable for Class II, Division 2, Groups F and G; and Class III, Division 2.   | Temperature Class T4A at 40°C and T4 at 85°C maximum ambient.      | F                        |
| <b>FM</b> explosionproof for Class I, Division 1, Groups B, C, and D; dust-ignitionproof for Class II, Division 1, Groups E, F, and G; and Class III, Division 1.   | Temperature Class T6 at 80°C and T5 at 85°C maximum ambient.       | F                        |
| <b>FM</b> field device zone certified flameproof AEx d IIC. Also, all certifications of Code F above.   | Temperature Class T6 at 75°C maximum ambient.                      | G                        |
| <b>IECEX</b> FISCO field device intrinsically safe; Ex ia IIC, Zone 0.  | Temperature Class T4; Ta = -40 to +80°C.                           | T                        |
| <b>IECEX</b> flameproof, Ex d IIC.  | T6, Ta = 80°C; T5, Ta = 85°C;<br>Ambient Temperature -20 to +85°C. | V                        |
| <b>IECEX</b> FNICO field device protection n: Ex nL IIC, Zone 2.  | Temperature Class T4; Ta = -40 to +80°C.                           | U                        |

## MODEL CODE

| <u>Description</u>   | <u>Model</u>  |                          |    |
|--|---------------|--------------------------|----|
| I/A Series, Multirange Differential Pressure Transmitter   | IDP25         |                          |    |
| <b><u>Electronics Versions and Output Signal</u></b>   |               |                          |    |
| Intelligent; Digital FoxCom or 4 to 20 mA dc, Configurable (Version -D)                                    | -D            |                          |    |
| Intelligent; Digital HART and 4 to 20 mA dc (Version -T)   | -T            |                          |    |
| Intelligent; Digital, FOUNDATION Fieldbus (Version -F)   | -F            |                          |    |
| <b><u>Structure Code - Select from one of the following six groups:</u></b>                                |               |                          |    |
| <b><u>1. Transmitter with Traditional Structure</u></b>  |               |                          |    |
| <b>Process Cover</b>   | <b>Sensor</b> | <b>Sensor Fill Fluid</b> |    |
| 316 ss   | 316L ss       | Silicone                 | 22 |
| 316 ss   | 316L ss       | Fluorinert               | 23 |
| 316 ss   | Hastelloy C   | Silicone                 | 26 |
| 316 ss   | Hastelloy C   | Fluorinert               | 27 |
| Hastelloy C  | Hastelloy C   | Silicone                 | 46 |
| Hastelloy C  | Hastelloy C   | Fluorinert               | 47 |
| <b><u>2. Transmitter with Low Profile Structure LP1 (Not available with Pressure Seals)</u></b>            |               |                          |    |
| <b>Process Cover</b>   | <b>Sensor</b> | <b>Sensor Fill Fluid</b> |    |
| 316 ss   | 316L ss       | Silicone                 | LL |
| 316 ss   | 316L ss       | Fluorinert               | LM |
| 316 ss   | Hastelloy C   | Silicone                 | LC |
| 316 ss   | Hastelloy C   | Fluorinert               | LD |
| Hastelloy C  | Hastelloy C   | Silicone                 | CC |
| Hastelloy C  | Hastelloy C   | Fluorinert               | CD |
| <b><u>3. Transmitter with Low Profile Structure LP2 (Not available with Pressure Seals)</u></b>            |               |                          |    |
| <b>Process Cover</b>   | <b>Sensor</b> | <b>Sensor Fill Fluid</b> |    |
| 316 ss   | 316L ss       | Silicone                 | 52 |
| 316 ss   | 316L ss       | Fluorinert               | 53 |
| 316 ss   | Hastelloy C   | Silicone                 | 56 |
| 316 ss   | Hastelloy C   | Fluorinert               | 57 |
| Hastelloy C  | Hastelloy C   | Silicone                 | 66 |
| Hastelloy C  | Hastelloy C   | Fluorinert               | 67 |
| <b><u>4. Transmitter prepared for Foxboro Model Coded Remote Mount Seals (a)(b)</u></b>                    |               |                          |    |
| Transmitter prepared for Remote Seals on Both HI and LO Sides, Silicone Fill in Sensor                     |               |                          | S1 |
| Transmitter prepared for Remote Seals on Both HI and LO Sides, Fluorinert Fill in Sensor                   |               |                          | S2 |
| Transmitter prepared for Remote Seal HI Side, 1/2 NPT Connector LO Side, Silicone Fill in Sensor           |               |                          | S3 |
| Transmitter prepared for Remote Seal HI Side, 1/2 NPT Connector LO Side, Fluorinert Fill in Sensor         |               |                          | S4 |
| Transmitter prepared for Remote Seal LO Side, 1/2 NPT Connector HI Side, Silicone Fill in Sensor           |               |                          | S5 |
| Transmitter prepared for Remote Seal LO Side, 1/2 NPT Connector HI Side, Fluorinert Fill in Sensor         |               |                          | S6 |
| <b><u>5. Transmitter Prepared for Foxboro Model Coded Direct Connect Seals (a)</u></b>                     |               |                          |    |
| PSFLT, PSSCT, or PSSST Direct Connect Seal on HI Side; 1/2 NPT Process Connector LO Side; Silicone Fill    |               |                          | F1 |
| PSFLT, PSSCT, or PSSST Direct Connect Seal on HI Side; 1/2 NPT Process Connector LO Side; Fluorinert Fill  |               |                          | F2 |
| PSFLT, PSSCT, or PSSST Direct Connect Seal on HI Side; Remote Seal with Capillary LO Side; Silicone Fill   |               |                          | F3 |
| PSFLT, PSSCT, or PSSST Direct Connect Seal on HI Side; Remote Seal with Capillary LO Side; Fluorinert Fill |               |                          | F4 |
| <b><u>6. Transmitter Prepared for non-Foxboro Seals</u></b>  |               |                          |    |
| Remote Seals on High and Low Sides; Silicone Fill in Sensor  |               |                          | SA |
| Remote Seals on High and Low Sides; Inert Fill in Sensor   |               |                          | SB |
| Remote Seal on High Side and 1/2 NPT Connector on Low Side, Silicone Fill in Sensor                        |               |                          | SC |
| Remote Seal on High Side and 1/2 NPT Connector on Low Side, Inert Fill in Sensor                           |               |                          | SD |
| Remote Seal on Low Side and 1/2 NPT Connector on High Side, Silicone Fill in Sensor                        |               |                          | SE |
| Remote Seal on Low Side and 1/2 NPT Connector on High Side, Inert Fill in Sensor                           |               |                          | SF |

Model Code continued on next page

**MODEL CODE (Cont.)**

| <b>Span Limits</b>  |                         |               |
|---|-------------------------|---------------|
| <b>kPa</b>  | <b>inH<sub>2</sub>O</b> | <b>mbar</b>   |
| 0.12 and 50   | 0.5 and 200             | 1.2 and 500   |
| 0.625 and 250   | 2.5 and 1000            | 6.25 and 2500 |
| <b>Process Connector Type (Material Same as Process Cover Material) (c)</b>   |                         |               |
| See below:  |                         | 0             |
| <ul style="list-style-type: none"> <li>For d/p: No connectors; both covers tapped for 1/4 NPT (316 ss only, no side vents)</li> <li>Flange Mount Hi Side: 1/2 NPT, 316 ss Process Connector on Lo Side (F1 and F2 only)</li> <li>Flange Mount Hi Side: No connectors; both sides prepared for seals (F3 and F4 only)</li> <li>Two Remote Seals: No connectors; both covers tapped for capillary connection (S1, S2, SA, SB only)</li> <li>One Remote Seal: 1/2 NPT, 316 ss Process Connector on Side Opposite Seal (S3 to S6, SC to SF only)</li> </ul> |                         |               |
| 1/4 NPT, Not with Structure Codes 46, 47, 66, 67, CC, or CD, or pressure seals  |                         | 1             |
| 1/2 NPT, Not with pressure seals  |                         | 2             |
| Rc 1/4, Not with Structure Codes 46, 47, 66, 67, CC, or CD; or pressure seals   |                         | 3             |
| Rc 1/2, Not with pressure seals   |                         | 4             |
| 1/2 Schedule 80 Welding Neck, Not with Structure Codes 46, 47, 66, 67, CC, or CD; or pressure seals   |                         | 6             |
| <b>Conduit Connection and Housing Material</b>  |                         |               |
| 1/2 NPT Conduit Connection, Aluminum Housing  |                         | 1             |
| PG 13.5 Conduit Connection, Aluminum Housing (With Electrical Safety Codes E, D, M, and N only)   |                         | 2             |
| 1/2 NPT Conduit Connection, 316 ss Housing  |                         | 3             |
| PG 13.5 Conduit Connection, 316 ss Housing (With Electrical Safety Codes E, D, M, and N only)   |                         | 4             |
| M20 Conduit Connection, Both Sides, Aluminum Housing (With Electrical Safety Codes E, D, M, and N only)   |                         | 5             |
| M20 Conduit Connection, Both Sides, 316 ss Housing (With Electrical Safety Codes E, D, M, and N only)   |                         | 6             |
| <b>Electrical Safety (Also see Electrical Safety Specifications section)</b>  |                         |               |
| ATEX II 1 GD, EEx ia IIC, Zone 0; or II 1/2 GD, EEx ib IIC, Zone 0/Zone 1 (Electronic Versions -D and -T only)  |                         | E             |
| ATEX FISCO, II 1 G, EEx ia IIC, Zone 0 (Electronic Version -F only)   |                         | E             |
| ATEX II 2 GD, EEx d IIC, Zone 1 (r)   |                         | D             |
| ATEX II 3 GD, EEx nL IIC, Zone 2 (Electronic Versions -D and -T only)   |                         | N             |
| ATEX FNICO, II 3 G, EEx nL IIC, Zone 2 (Electronic Version -F only)   |                         | N             |
| ATEX Multiple Certifications (includes ATEX Codes E, D, and N) (Electronic Versions -D and -T only) (r)   |                         | M             |
| (See Electrical Safety Specifications section for <u>user marking</u> )   |                         |               |
| CSA Certifications:   |                         | C             |
| Intrinsically Safe, Division 1 (Versions D & T only)  |                         |               |
| Zone Certified Ex ia IIC and Ex nA II (Version T only)  |                         |               |
| Explosionproof and dust-ignitionproof, Division 1   |                         |               |
| Division 2, Class I, II, and III (Versions D & T only)  |                         |               |
| FISCO, intrinsically safe, Division 1 (Version F only)  |                         |               |
| FNICO, nonincendive, Division 2 (Version F only)  |                         |               |
| Zone certified Ex ia IIC (Version F only)   |                         |               |
| CSA Certification:  |                         | B             |
| Zone certified flameproof Ex d IIC. Also all certifications of Code C above   |                         |               |
| FM Approvals:   |                         | F             |
| Intrinsically Safe, Division 1 (Versions D and T only)  |                         |               |
| Zone approved AEx ia IIC (Versions F and T only)  |                         |               |
| Explosionproof and dust-ignitionproof, Division 1   |                         |               |
| Nonincendive, Division 2, Class I, II, III (Versions D and T only)  |                         |               |
| FISCO, intrinsically safe, Division 1 (Version F only)  |                         |               |
| FNICO, nonincendive, Division 2 (Version F only)  |                         |               |
| FM Approvals:   |                         | G             |
| Zone approved flameproof AEx d IIC. Also all approvals of Code F above  |                         |               |
| IECEx FISCO, Ex ia IIC, Zone 0 (Version -F only)  |                         | T             |
| IECEx, flameproof, Ex d IIC   |                         | V             |
| IECEx FNICO, Ex nL IIC, Zone 2 (Version -F only)  |                         | U             |
| SAA intrinsically safe, Ex ia IIC, Zone 0. (Version T only)   |                         | H             |
| SAA nonincendive, Ex n IIC, Zone 2. (Version T only)  |                         | K             |

**MODEL CODE (Cont.)**

|  |     |
|--|-----|
| <b>Optional Selections</b>   |     |
| Refer to Optional Selections below.  |     |
| <b>Mounting Bracket Set (d)</b>  |     |
| Standard Style Painted Steel Bracket with Plated Steel Bolts   | -M1 |
| Standard Style Stainless Steel Bracket with Stainless Steel Bolts  | -M2 |
| Universal Style Stainless Steel Bracket with Stainless Steel Bolts (q)   | -M3 |
| <b>Digital Indicator with Pushbuttons</b>  |     |
| Digital Indicator, Pushbuttons, and Window Cover   | -L1 |
| <b>DIN 19213 Construction used with Process Connector Code 0 and 316 ss Covers with no side vents (e)</b>  |     |
| Single Ended Process Cover with M10, B7 Steel Bolting (f)(s)   | -D1 |
| Double Ended Process Cover with M10, B7 Steel Bolting; Blind Kidney Flange on Back (f)(g)(h)   | -D2 |
| Single Ended Process Cover with 7/16 in, B7 Steel Bolting; Standard Rating 25 MPa (3625 psi) (s)   | -D3 |
| Double Ended Process Cover with 7/16 in, B7 Steel Bolting; Blind Kidney Flange on Back (f)(g)(h)   | -D4 |
| Single Ended Process Cover with 7/16 in, 316 ss Bolting (f)(s)   | -D5 |
| Double Ended Process Cover with 7/16 in, 316 ss Bolting; Blind Kidney Flange on Back (f)(g)(h)   | -D6 |
| Single Ended Process Cover with 7/16 in, 17-4 ss Bolting; Standard Rating 25 MPa (3625 psi) (s)  | -D7 |
| Double Ended Process Cover with 7/16 in, 17-4 ss Bolting; Blind Kidney Flange on Back (f)(g)(h)  | -D8 |
| Single Ended Process Cover with 7/16 in, 17-4 ss Bolting; Rated 400 bar, 5800 psi, 40 MPa (s)  | -D9 |
| Not available with Span Codes A, D, or E; or Option Codes -V, -B1, -B2, -B3, or -Y   |     |
| <b>Cleaning and Preparation (e)</b>  |     |
| Unit Degreased - for Silicone Filled Sensors Only<br>(Not for Oxygen/Chlorine/Other Fluids that may react with Silicone)                                       | -X1 |
| Cleaned and Prepared for Oxygen Service - for Fluorinert Filled Sensors Only<br>(Not Available with Carbon Steel Covers or with Silicone Filled Sensors)       | -X2 |
| Cleaned and Prepared for Chlorine Service - for Fluorinert Filled Sensors Only (j)<br>(Not Available with Carbon Steel Covers or with Silicone Filled Sensors) | -X3 |
| <b>Bolting for Process Covers/Connectors (k)</b>   |     |
| 316 ss Bolts and Nuts (Pressure Derated; Not Available with -Y Option) (f)   | -B1 |
| 17-4 ss Bolts and Nuts (j)   | -B2 |
| B7M Bolts and Nuts (NACE) (f)  | -B3 |
| <b>Conduit Thread Adapters (Not available with Conduit Connection Codes 5 and 6)</b>   |     |
| Hawke-Type 1/2 NPT Cable Gland for use with Conduit Connection Codes 1 and 3 (l)   | -A1 |
| Plastic PG 13.5 Cable Gland for use with Conduit Connection Codes 2 and 4 (m)  | -A2 |
| M20 Conduit Thread Adapter for use with Conduit Connection Codes 1 and 3 (l)   | -A3 |
| Brass PG 13.5 Cable Gland (Trumpet-Shaped) for use w/Conduit Connection Codes 2 and 4 (m)  | -A4 |
| <b>Electronics Housing Features</b>  |     |
| External Zero Adjustment   | -Z1 |
| Custody Transfer Lock and Seal   | -Z2 |
| External Zero Adjustment and Custody Transfer Lock/Seal  | -Z3 |
| <b>Custom Factory Configuration</b>  |     |
| Digital Output (4 to 20 mA default if not selected); for Electronics Version -D only   | -C1 |
| Full Factory Configuration (Requires Configuration Form to be Filled Out)  | -C2 |
| <b>Tubing Connectors</b>   |     |
| 316 ss, Connecting 6 mm Tubing to 1/4 NPT Process Connector<br>Only with Structure Codes 22 and 23; and Process Connector Codes 0 and 1                        | -E3 |
| 316 ss, Connecting 12 mm Tubing to 1/2 NPT Process Connector<br>Only with Structure Codes 22 and 23; and Process Connector Code 2                              | -E4 |
| <b>Vent Screw in Process Cover</b>   |     |
| Supply Vent Screw in Side of Each Process Cover<br>(Available only with Structure Codes 22 to 47)  | -V  |
| Omit Vent Screw in Side of Each Process Cover<br>(Available only with Structure Codes LL, LM, LC, LD, CC, and CD)  | -V1 |

Model Code continued on next page

**MODEL CODE (Cont.)**

| <b>Optional Selections (Cont.)</b>   |     |
|--|-----|
| <b>Adapter Plate, Bolts, and Gaskets for Direct Mount to Competitive Manifolds (t)</b>                   |     |
| See inside pages for manifold compatibility.   |     |
| Adapter Set for MC Coplanar Manifolds, B7 Bolts (not with options -B1, -B2, or -B3)                      | -P1 |
| Adapter Set for MC Coplanar Manifolds, 316 ss Bolts (requires -B1 option)                                | -P2 |
| Adapter Set for MC Coplanar Manifolds, 17-4 ss Bolts (requires -B2 option)                               | -P3 |
| Adapter Set for MC Coplanar Manifolds, B7M Bolts (requires -B3 option)                                   | -P4 |
| Adapter Set for MT3 Coplanar Manifolds, Traditional Flange, B7 Bolts (not with options -B1, -B2, or -B3) | -P5 |
| Adapter Set for MT3 Coplanar Manifolds, Traditional Flange, 316 ss Bolts (requires -B1 option)           | -P6 |
| Adapter Set for MT3 Coplanar Manifolds, Traditional Flange, 17-4 ss Bolts (requires -B2 option)          | -P7 |
| Adapter Set for MT3 Coplanar Manifolds, Traditional Flange, B7M Bolts (requires -B3 option)              | -P8 |
| <b>Gaskets</b>   |     |
| Metal O-ring for pressure seals in vacuum service (n)  | -G1 |
| Available only with Structure Codes IDP25-.S. and IDP25-.F.  |     |
| <b>Instruction Books (Common MI, Brochure, and Full Documentation Set on CD-ROM is Standard)</b>         |     |
| Without Instruction Book and CD; only "Getting Started" brochure is supplied.                            | -K1 |
| <b>Miscellaneous Optional Selections</b>   |     |
| Low Temperature Operative Limit of Electronics Housing Extended Down to -50°C (-58°F)                    | -J  |
| Not available with sensors and seals with fluorinert fill; and   |     |
| Not available with DIN Options -D2, -D4, -D6, and -D8  |     |
| Supplemental Customer Tag (Stainless Steel Tag wired onto Transmitter)                                   |     |
| Seventeen Year Warranty (v)  | -T  |
| Static Pressure Rating to 40 MPa (5800 psi);   | -W  |
| Not available with:  | -Y  |
| - Options -B1, -B2, and -B3 (p)  |     |
| - Options -D1 to -D9   |     |
| - Structure Codes S1 to S6, SA to SF, and F1 to F4   |     |
| Example: IDP25-T22C11F-M2L1Z1T   |     |

- (a) Both Transmitter and Pressure Seal Model Numbers are required. See PSS 2A-1Z11 A for the various pressure seal Model Codes.
- (b) Remote Seal Models that may be specified are PSFPS, PSFES, PSFAR, PSTAR, PSISR, PSSCR, and PSSSR.
- (c) Select Code "0" if a pressure seal is specified. Otherwise select Code 1 through 6.
- (d) Mounting sets not offered with direct connect (flange mount) seals.
- (e) Not available when Remote Mount or Direct Connect (Flanged Level) Seals are specified.
- (f) See Functional Specifications section for pressure deratings when some DIN 19213 options and Bolting Options -B1/-B3 are specified.
- (g) Temperature limits derated to 0 and 60°C (32 and 140°F). Also not available with Structure Codes 52 to 57, and LL, LM, LC, and LD.
- (h) Mounting Bracket Set options are not available.
- (j) When -X3 is specified, the standard bolting is replaced with 17-4 ss bolts and nuts. Therefore, there is no need to specify Option -B2 when selecting the Chlorine Service Option -X3.
- (k) Not available with DIN construction options. For stainless steel bolts with DIN construction, specify -D5 to -D9, as required.
- (l) Available with Electric Safety Codes E, D, M, and N only.
- (m) Available with Electrical Safety Code E only.
- (n) -G1 is a required option when pressure seal will be used in vacuum applications. This option substitutes vacuum service metal gasket for standard ptfе process cover gasket.
- (p) -B2 Bolt Option (17-4 ss) is not available with the -Y option because 17-4 ss bolts and nuts are supplied as part of the -Y option.
- (q) Bracket Set Option -M3 is not available with Structure Codes LL, LM, LC, LD, CC, or DD.
- (r) A cover lock is provided as standard with Electrical Safety Codes D, B, G, and M.
- (s) Not available with Low Profile Structure Codes 52-57.
- (t) Adapter plate options -P1 to -P8 are not available with:
  - Pressure Seal Structure Codes.
  - Process Connector Codes 1-7.
  - DIN Construction Options -D1, -D2, -D4, -D5, -D6, -D7, -D8, -D9.
- (v) Standard Warranty is five years.

---

### SUGGESTED RFQ SPECIFICATIONS

The manufacturer shall provide multirange field-mounted differential pressure transmitters featuring FoxCom, HART, or FOUNDATION Fieldbus Communication Protocol. They shall provide remote digital communications capability for measuring differential pressure, and transmit a digital, or 4 to 20 mA dc (FoxCom and HART only), output signal for use in a standard two-wire dc supply voltage system. These transmitters shall also be provided (as required) with direct connect seals, or remote mount, capillary connected seals. The specifications for these transmitters are as follows:

|  |   |
|--|---|
| <b>Communication Protocol:</b>                         | FoxCom: Digital or 4 to 20 mA dc output signal (configurable)<br>HART: Digital and 4 to 20 mA dc output signal<br>FOUNDATION Fieldbus: Digital output signal  |
| <b>Remote Communications:</b>                          | Must not interfere with output  |
| <b>Span Turndown Ratio:</b>                            | 400:1   |
| <b>Accuracy:</b>                                       | ±0.050% of calibrated span for spans ≥1.25% of URL.   |
| <b>Damping:</b>  | Settable for a range of none to 32 seconds  |
| <b>RFI Protection:</b>                                 | 0.1% error between 27 and 1000 MHz at 30 V/m field intensity  |
| <b>Proof Pressure:</b>                                 | 14 500 psi for standard transmitter   |
| <b>Span Limits:</b>                                    | 0.5 and 200 inH <sub>2</sub> O, or 2.5 and 1000 inH <sub>2</sub> O, as specified; or SI and metric equivalents.   |
| <b>Mounting:</b>                                       | On process piping, manifold, or optional mounting bracket   |
| <b>Input Connection:</b>                               | With process connectors to accept 1/4 NPT, 1/2 NPT, Rc 1/4 or Rc 1/2, 1/2 Schedule 80 welding neck; or prepared for a direct connect seal; or prepared for a single remote capillary connected seal, or two remote capillary connected seals.   |
| <b>Electronics Housing:</b>                            | 316 ss, or aluminum housing with epoxy finish   |
| <b>Modular Electronics:</b>                            | Easily replaceable modular electronics in a NEMA 4X (IEC IP66) housing sealed with O-rings for protection against moisture or other contaminants. Optional integral LCD Indicator with on-board configuration pushbuttons.  |
| <b>Process Cover:</b>                                  | Traditional Structures<br>316 ss or Hastelloy C<br>Low Profile Structures:<br>316 ss or Hastelloy C   |
| <b>Sensor Materials:</b>                               | Traditional Structure:<br>316L ss or Hastelloy C<br>Low Profile Structures:<br>316L ss or Hastelloy C   |
| <b>Approvals and Certifications:</b>                   | Must be suitable for Division 1 hazardous locations, and conform to all applicable European Union Directives; also versions available to meet Agency flameproof and zone requirements. Also FOUNDATION Fieldbus versions must be FISCO and FNICO compliant.                                       |
| <b>Approximate Mass:<br/>(with Process Connectors)</b> | 4.2 kg (9.2 lb), with Traditional Structures;<br>Add 0.1 kg (0.2 lb) with Low Profile Structure LP1;<br>Add 0.8 kg (1.8 lb) with Low Profile Structure LP2;<br>Add 1.1 kg (2.4 lb) with 316 ss housing;<br>Add 0.2 kg (0.4 lb) with optional LCD indicator.<br>Pressure seal(s) mass is additive. |
| <b>Model Code:</b>                                     | I/A Series Intelligent Multirange IDP25 d/p Cell Transmitter with either FoxCom, HART, or FOUNDATION Fieldbus Communication Protocol, or equivalent, with or without pressure seals, or equivalent  |

**DIMENSIONS - NOMINAL**

**mm  
in**

**TRANSMITTER WITH TRADITIONAL STRUCTURE**

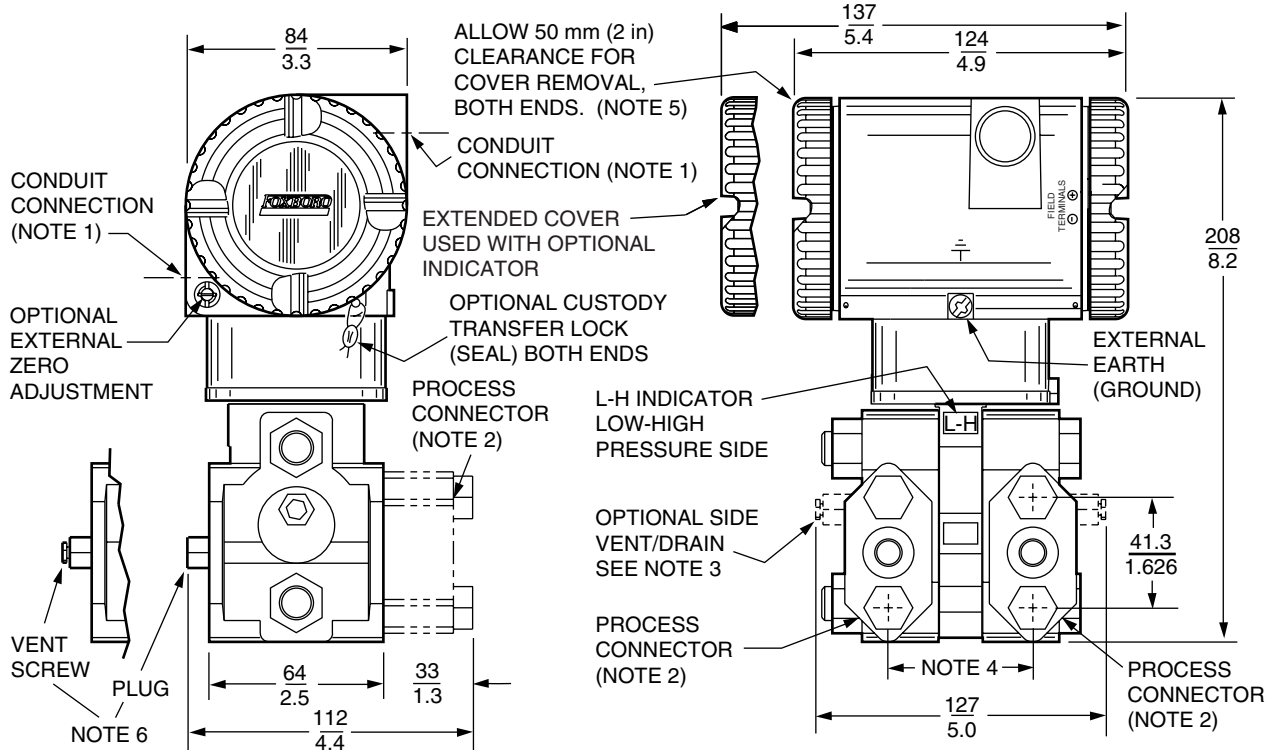

**NOTES:**

1. CONDUIT CONNECTION 1/2 NPT OR PG 13.5 OR M20, BOTH SIDES: PLUG UNUSED CONNECTION WITH METAL PLUG (SUPPLIED).
2. PROCESS CONNECTORS MAY BE REMOVED AND CONNECTIONS MADE DIRECTLY TO PROCESS COVER USING 1/4 NPT INTERNAL THREAD IN PROCESS COVER.
3. PROCESS COVER CAN BE INVERTED MAKING OPTIONAL SIDE VENTS OR SIDE DRAINS
4. PROCESS CONNECTORS CAN BE INVERTED TO GIVE EITHER 51, 54, OR 57 mm (2.0, 2.125, OR 2.25 in) CENTER-TO-CENTER DISTANCE BETWEEN HIGH AND LOW PRESSURE CONNECTIONS.
5. TOPWORKS CAN BE ROTATED TO ANY POSITION WITHIN ONE TURN COUNTERCLOCKWISE OF THE FULLY TIGHTENED POSITION.
6. PROCESS COVER END PLUGS ARE SUBSTITUTED FOR VENT SCREWS WHEN OPTIONAL SIDE VENTS (NOTE 3) ARE SPECIFIED.

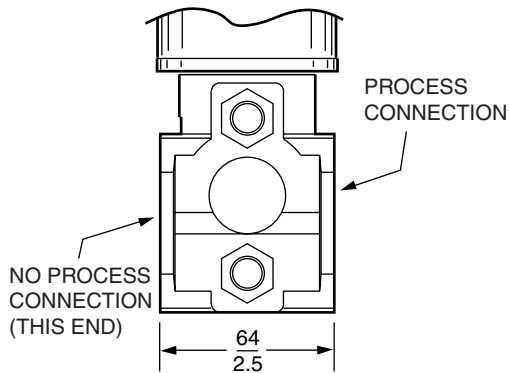

OPTIONAL DIN CONSTRUCTION  
SINGLE ENDED PROCESS COVER  
OPTIONS -D1, -D3, -D5, -D7, -D9

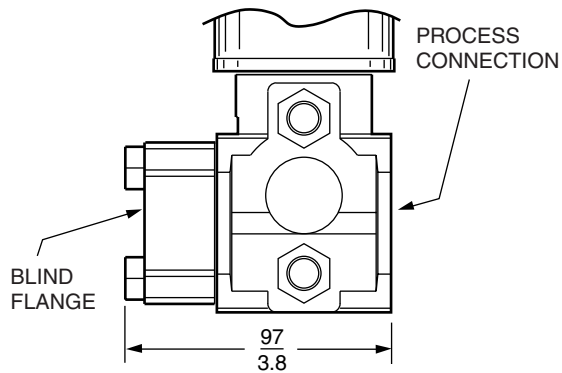

OPTIONAL DIN CONSTRUCTION  
DOUBLE ENDED PROCESS COVER  
OPTIONS -D2, -D4, -D6, AND -D8

DIMENSIONS - NOMINAL (Cont.)

mm  
in

TRANSMITTER WITH LOW PROFILE STRUCTURE LP1

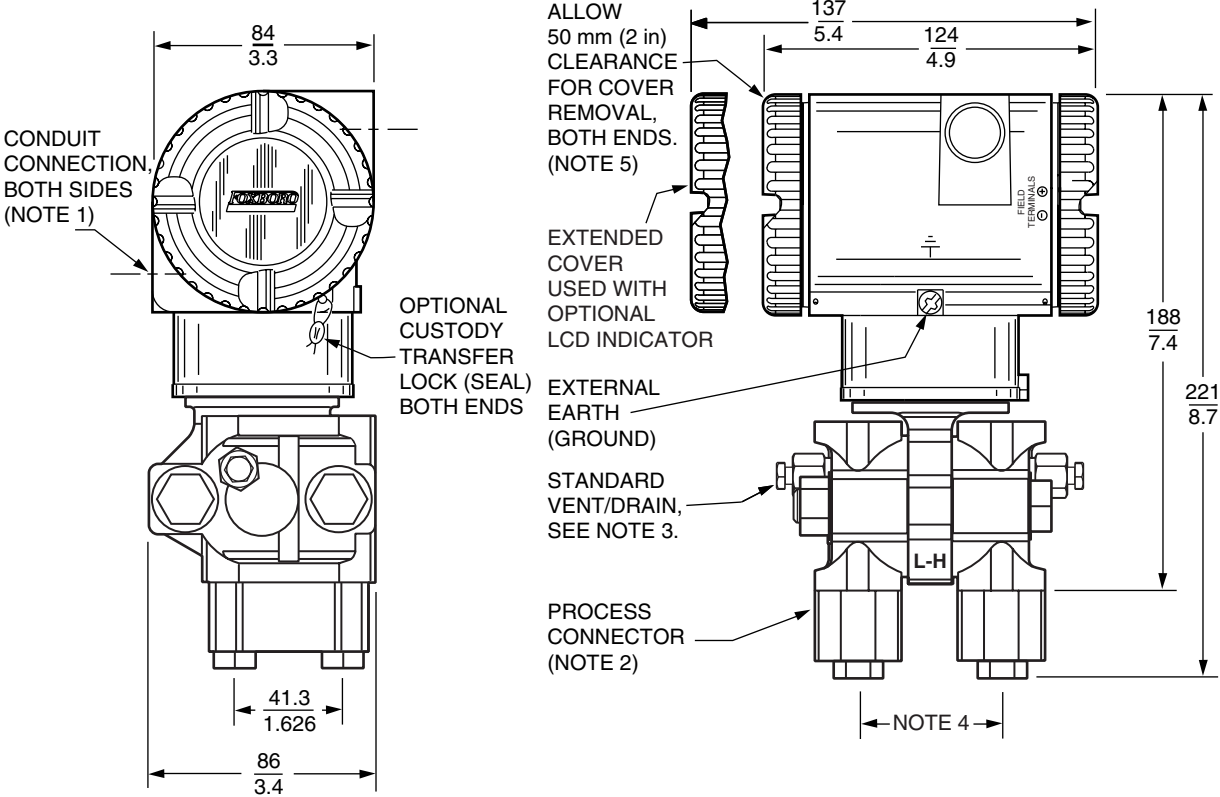

NOTES:

1. CONDUIT CONNECTION 1/2 NPT, PG 13.5, OR M20, BOTH SIDES: PLUG UNUSED CONNECTION WITH METAL PLUG (SUPPLIED).
2. PROCESS CONNECTORS MAY BE REMOVED AND TRANSMITTER MOUNTED DIRECTLY ON A MANIFOLD, OR CONNECTIONS MADE DIRECTLY TO PROCESS COVER USING 1/4 NPT INTERNAL THREAD IN PROCESS COVER.
3. THE TRANSMITTER'S LOW PROFILE STRUCTURE LP1 IS SHOWN IN THE VERTICALLY UPRIGHT POSITION. NOTE THE LOCATION OF THE STANDARD VENT/DRAIN SCREW. IN THIS CONFIGURATION THE TRANSMITTER CAN BE VENTED OR IS SELF-DRAINING. ALSO RECOMMENDED IS A HORIZONTAL INSTALLATION WHERE THE INSTALLED ORIENTATION CAN BE SET TO ALLOW FOR VENTING OR DRAINING.
4. PROCESS CONNECTORS CAN BE INVERTED TO GIVE EITHER 51, 54, OR 57 mm (2.0, 2.125, OR 2.25 in) CENTER-TO-CENTER DISTANCE BETWEEN HIGH AND LOW PRESSURE CONNECTIONS.
5. TOPWORKS CAN BE ROTATED TO ANY POSITION WITHIN ONE TURN COUNTERCLOCKWISE OF THE FULLY TIGHTENED POSITION.

**DIMENSIONS - NOMINAL (Cont.)**

**mm**  
**in**

**TRANSMITTER WITH LOW PROFILE STRUCTURE LP2**

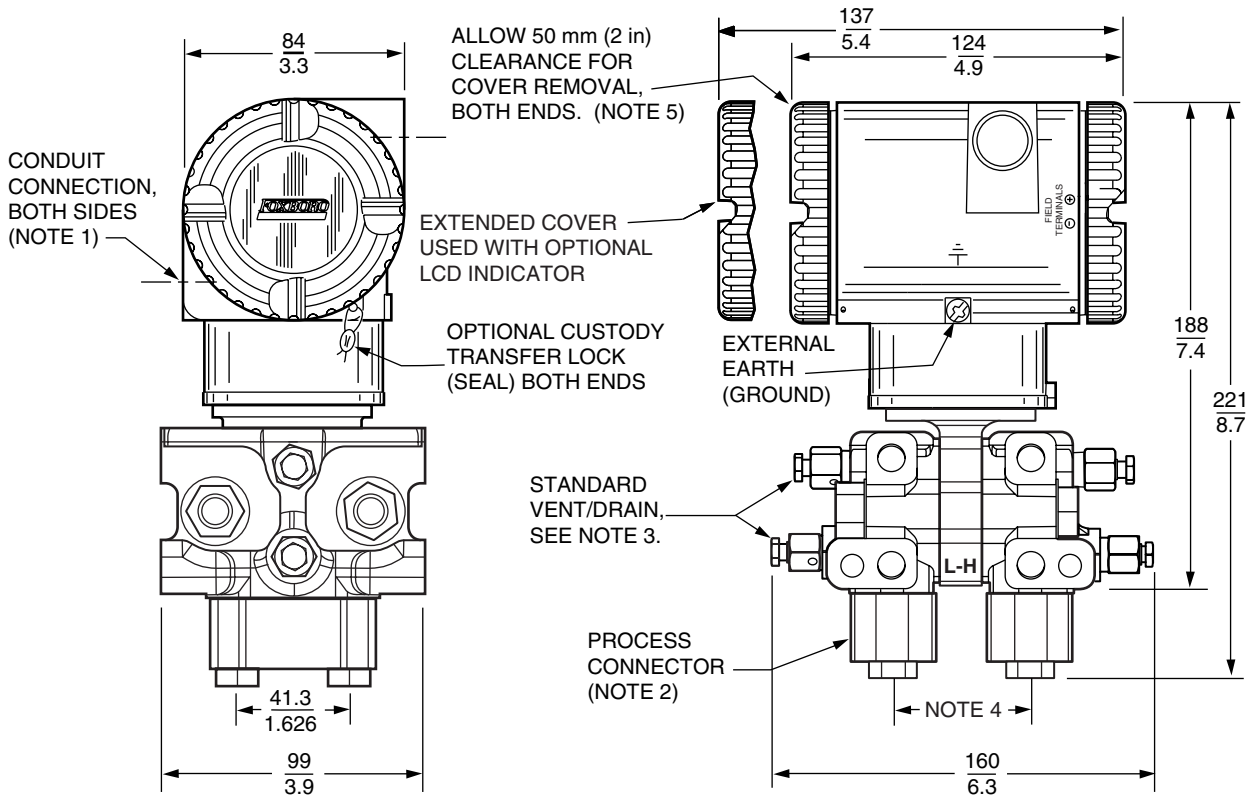

**NOTES:**

1. CONDUIT CONNECTION 1/2 NPT, PG 13.5, OR M20, BOTH SIDES: PLUG UNUSED CONNECTION WITH METAL PLUG (SUPPLIED).
2. PROCESS CONNECTORS MAY BE REMOVED AND TRANSMITTER MOUNTED DIRECTLY ON A MANIFOLD, OR CONNECTIONS MADE DIRECTLY TO PROCESS COVER USING 1/4 NPT INTERNAL THREAD IN PROCESS COVER.
3. THE TRANSMITTER'S LOW PROFILE STRUCTURE LP2 IS SHOWN IN THE RECOMMENDED VERTICAL UPRIGHT POSITION. NOTE THE STANDARD VENT OR DRAIN SCREWS. HORIZONTAL INSTALLATIONS ARE NOT RECOMMENDED.
4. PROCESS CONNECTORS CAN BE INVERTED TO GIVE EITHER 51, 54, OR 57 mm (2.0, 2.125, OR 2.25 in) CENTER-TO-CENTER DISTANCE BETWEEN HIGH AND LOW PRESSURE CONNECTIONS.
5. TOPWORKS CAN BE ROTATED TO ANY POSITION WITHIN ONE TURN COUNTERCLOCKWISE OF THE FULLY TIGHTENED POSITION.

DIMENSIONS - NOMINAL (Cont.)

$\frac{\text{mm}}{\text{in}}$

TRANSMITTER WITH STANDARD STYLE MOUNTING BRACKET KIT  
OPTIONS -M1 AND -M2

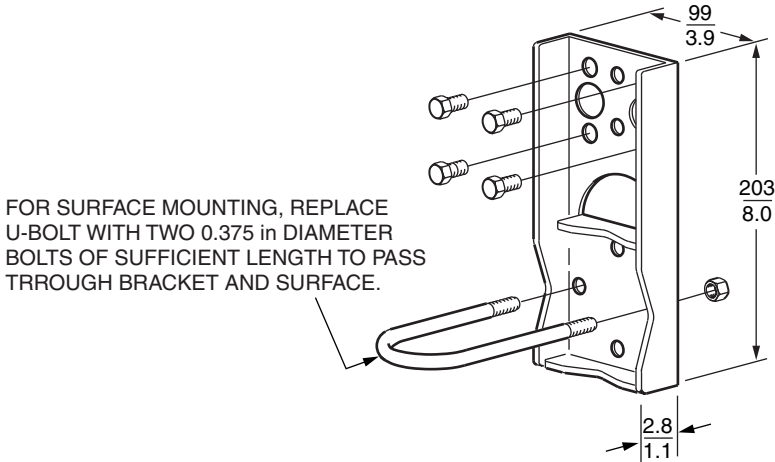

TRANSMITTER WITH TRADITIONAL STRUCTURE

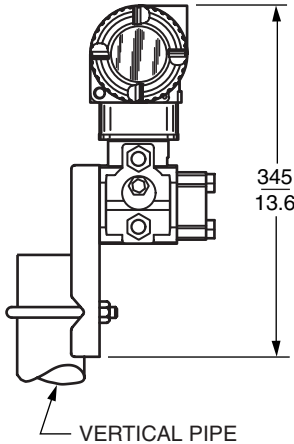

TRANSMITTER WITH LOW PROFILE STRUCTURE LP2

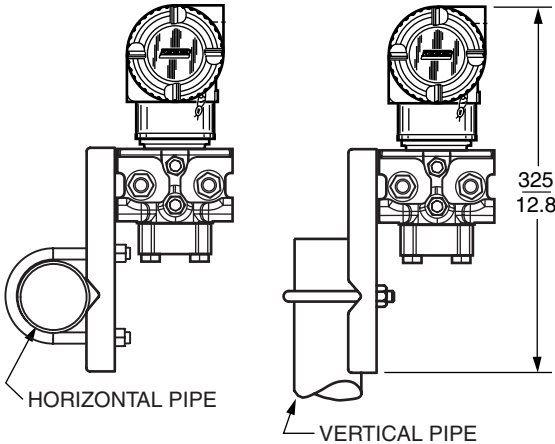

**DIMENSIONS - NOMINAL (Cont.)**

**mm**  
**in**

**TRANSMITTER WITH UNIVERSAL STYLE MOUNTING BRACKET KIT  
OPTION -M3**

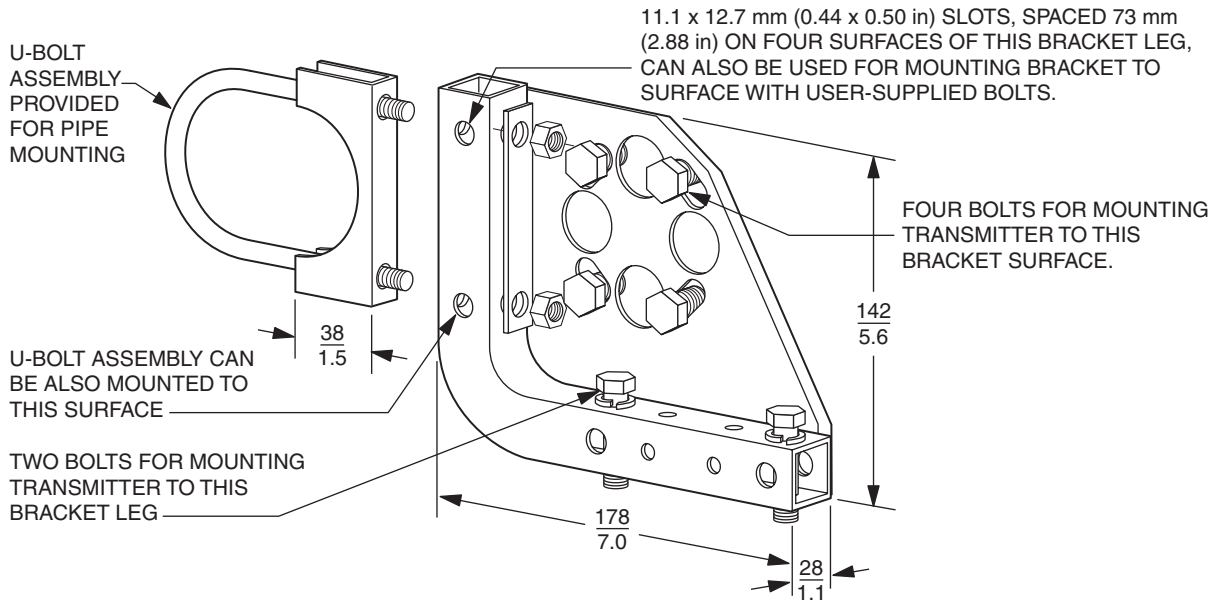

**TYPICAL PIPE MOUNTING WITH LOW PROFILE STRUCTURE LP2**

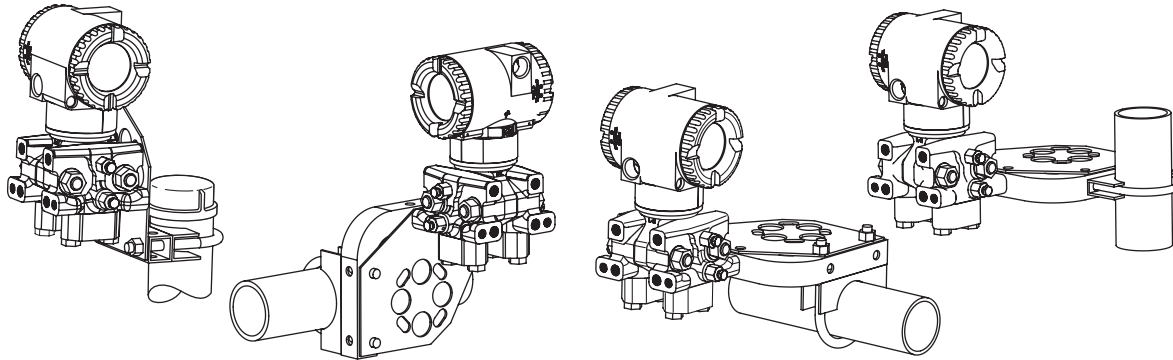

**TYPICAL PIPE MOUNTING  
LOW PROFILE STRUCTURE LP1**

**TYPICAL PIPE MOUNTING  
WITH TRADITIONAL STRUCTURE**

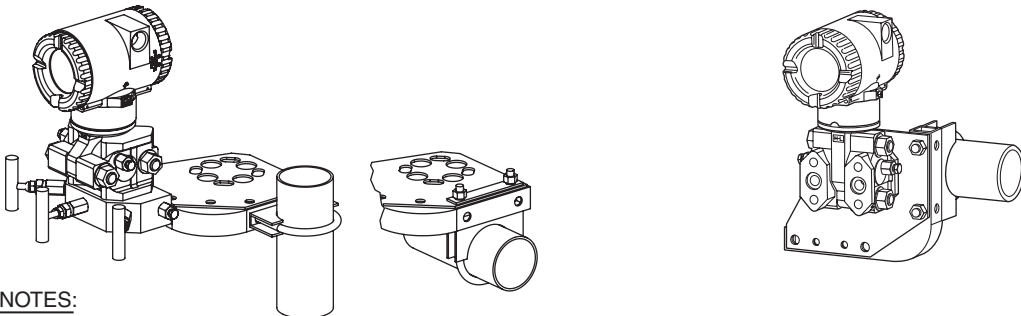

**NOTES:**

1. FOR SURFACE MOUNTING CONFIGURATIONS, USE THE U-BOLT MOUNTING HOLES FOR ATTACHING THE BRACKET TO A SURFACE RATHER THAN TO THE U-BOLT ASSEMBLY. SURFACE MOUNTING BOLTS FOR ATTACHING THE BRACKET TO A SURFACE ARE USER SUPPLIED.
2. REFER TO DIMENSIONAL PRINT DP 020-446 FOR FURTHER IDP25 MOUNTING CONFIGURATIONS, INCLUDING MOUNTING WITH -P SERIES OPTIONAL MOUNTING PLATES.







**ORDERING INSTRUCTIONS**

1. Model Number(s) as follows:
  - Transmitter only if pressure seals are not selected
  - Both transmitter and pressure seal if pressure seal is selected.
 See PSS 2A-1Z11 A.
2. Calibrated Pressure Range (using Allowable Pressure Units from the table below).
3. Configuration Data Form when Factory Calibration Option -C2 is specified.
4. Options and Accessories not in Model Code (see PSS 2A-1Z9 E).
5. User Tag Data - Data Plate; 32 characters maximum. For additional tag data, specify Optional Supplemental Tag -T.
6. User Tag Data - Software (Database):
  - FoxCom, -D; 12 characters maximum
  - HART, -T; 8 characters maximum
  - Fieldbus, -F; 32 characters maximum.

Allowable Pressure Units for Calibrated Range

|                    |                        |                        |      |                   |                    |
|--------------------|------------------------|------------------------|------|-------------------|--------------------|
| inH <sub>2</sub> O | cmH <sub>2</sub> O (a) | cmHg (a)               | kPa  | mbar              | kg/cm <sup>2</sup> |
| ftH <sub>2</sub> O | inHg                   | dy/cm <sup>2</sup> (a) | MPa  | bar               | psia               |
| mmH <sub>2</sub> O | mmHg                   | Pa                     | torr | g/cm <sup>2</sup> | atm                |

(a) Available with FoxCom Electronics (-D) only.

**OTHER M&I PRODUCTS**

Invensys Process Systems provides a broad range of measurement and instrument products, including solutions for pressure, flow, analytical, positioners, temperature, controlling and recording. For a listing of these offerings, visit the Invensys Foxboro web site at:

[www.foxboro.com/instrumentation](http://www.foxboro.com/instrumentation)

33 Commercial Street  
 Foxboro, MA 02035-2099  
 United States of America  
[www.foxboro.com](http://www.foxboro.com)  
 Inside U.S.: 1-866-746-6477  
 Outside U.S.: 1-508-549-2424  
 or contact your local Foxboro  
 representative.  
 Facsimile: 1-508-549-4999

Invensys, Foxboro, d/p Cell, Fox, Fox Com, and I/A Series are trademarks of Invensys plc, its subsidiaries, and affiliates.  
 All other brand names may be trademarks of their respective owners.

Copyright 2001-2008 Invensys Systems, Inc.  
 All rights reserved

MB 010

Printed in U.S.A.

0608