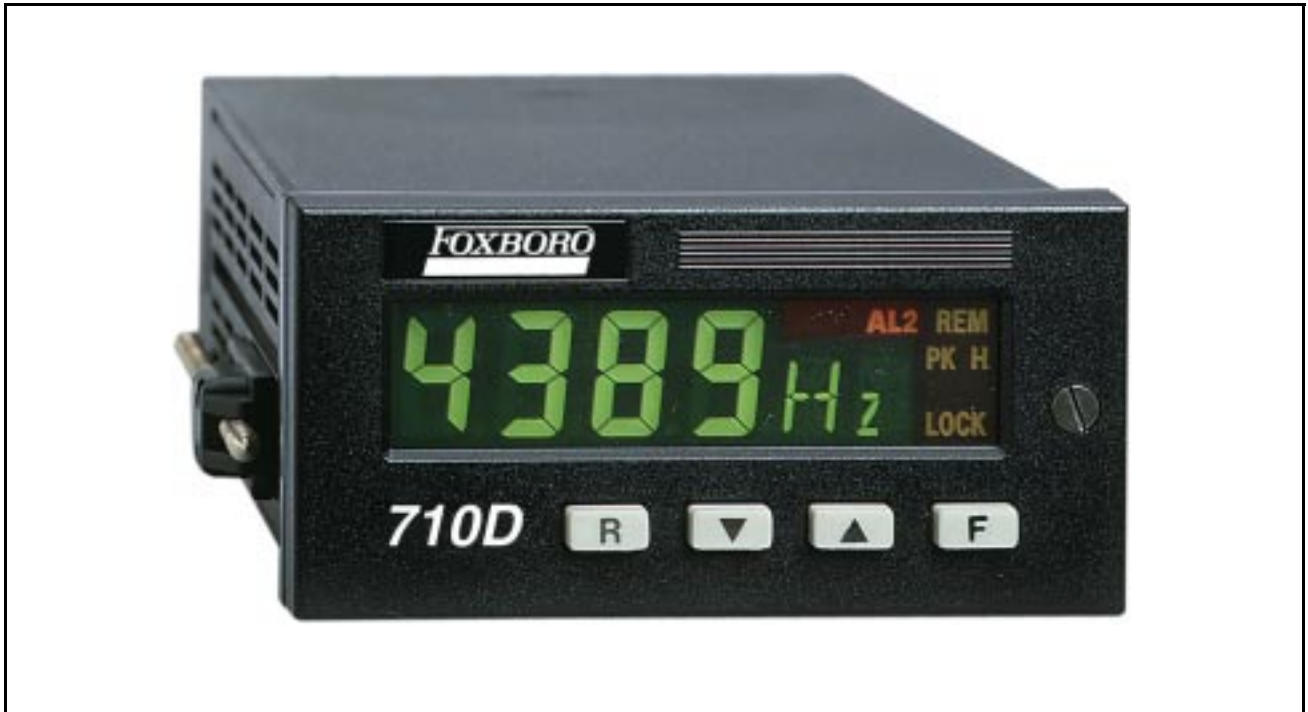

I/A Series[®] 710D 1/8 DIN Digital Indicator

The Foxboro 710D microprocessor-based indicator offers outstanding performance features in a cost effective package. Designed specifically for equipment manufacturers who demand tight process monitoring, the 710D has a variety of standard features commonly found only as options on competitive indicators.

The 710D high quality display station expands performance and functionality. Features such as 10-segment characterizers, transmitter power supply, analog retransmission, and advanced alarming give you the tools needed for low cost reliable indication and alarming. Modbus RS-485 serial interface provides communication when data collection capabilities and remote operation are needed. The IP54 faceplate allows this unit to be used in applications where dust conditions exist.

The man/machine interface provides a three-color customized display with two alphanumeric characters, one four-digit process display, and six status indicators.

FEATURES

- 3-color backlit LCD display
- Accurate to 0.1% full scale
- Universal input (T/C, RTD, mV, V, mA)

- IP54 protection
- 100 to 240 V ac switching power supply
- Up to two independent alarms configurable with automatic or manual reset
- Memory for high and low peak readings
- Square root extractor
- Configurable 10-segment characterizer
- Transmitter power supply
- Peak High/Peak Low Detection
- Analog input filter
- Security "Software Key"
- Conforms to the applicable European Union directives (symbolized by the "CE" Logo marking on the product)

OPTIONAL FEATURES

- Isolated analog retransmission signal
- Isolated auxiliary power supply
- RS-485 digital communications
- 24 V power supply

APPLICATIONS

Flow

Flow measurement by Venturi tube or orifice plate. In this example, the transmitter measures the differential pressure across the Venturi tube or orifice plate. The 710D calculates the square root of the input signal and scales it for local viewing. A retransmitted signal, 0 to 20 mA or 4 to 20 mA, can be sent to a controller or recorder for data collection and control.

Level

Level measurement in a tank with nonlinear ratio between volume and height. The 710D can display tank volume in engineering units, even with tanks of non-uniform slopes, by matching the 10-segment characterizer to the tank slope. The process variable and alarm status are displayed and retransmitted to a workstation for trending, data collection, and SPC via the RS-485 Modbus connection.

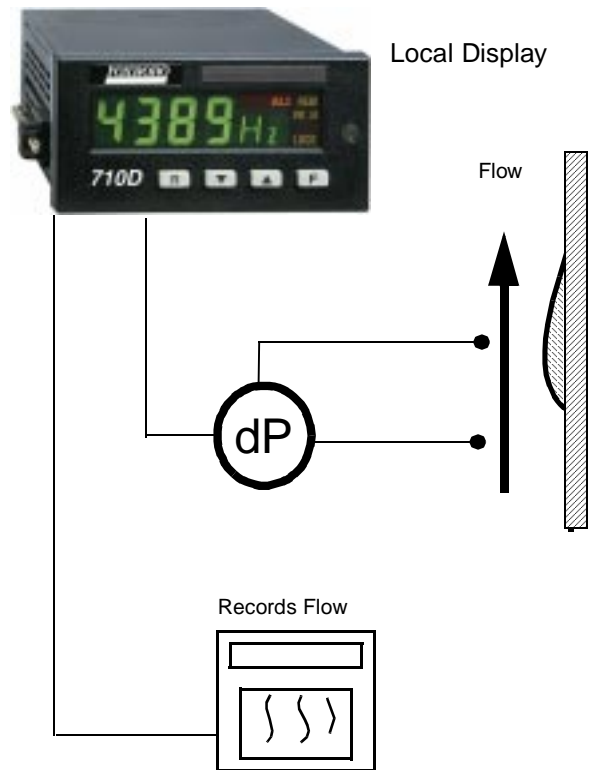

Figure 1. Typical Flow Measurement

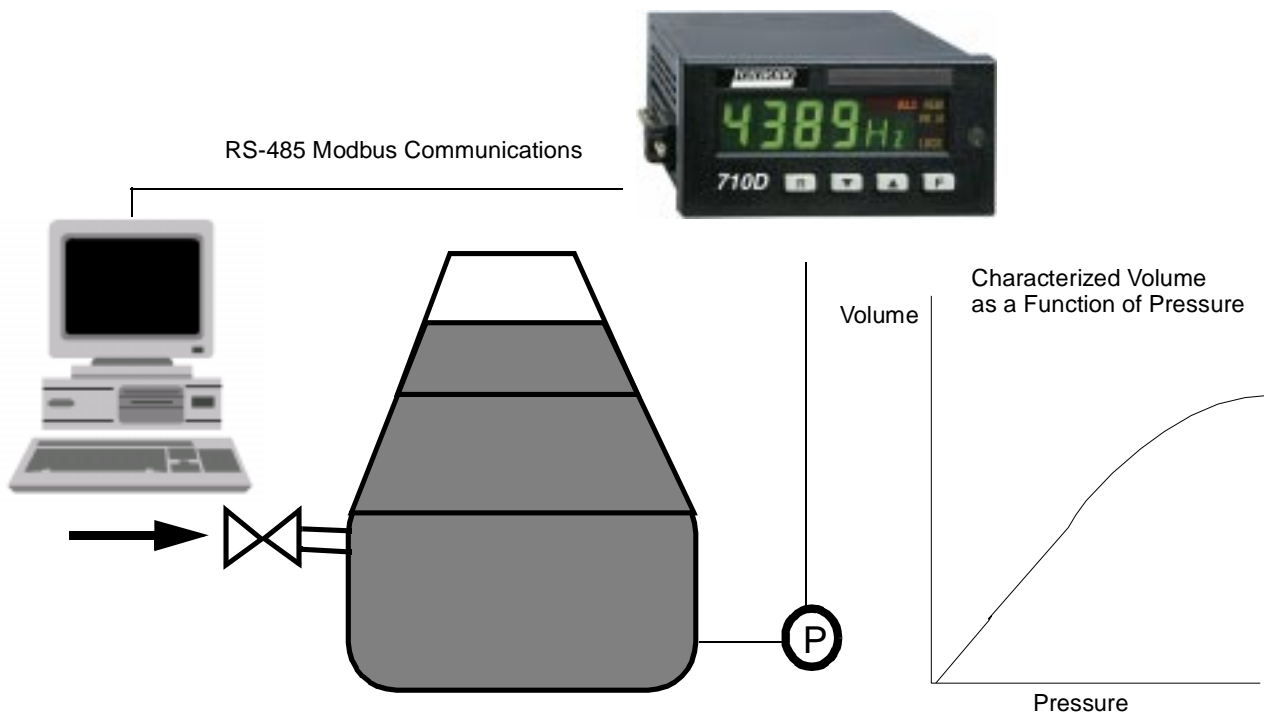

Figure 2. Typical Tank Volume Measurement with Nonlinear Tank Slope

Operator Interface

Numeric Display

The numeric display continuously shows the process variable in engineering units.

During configuration and calibration procedures, this display is used in addition to the alphanumeric display to show the parameter name and the relative value.

Alphanumeric Display

The alphanumeric display normally shows the engineering units of the displayed value.

During configuration and calibration procedures, this display is used in addition to the numeric display to show the parameter name and the relative value.

Descriptions of the displays are shown below.

Indicator	Description
AL1	Alarm 1 condition indicator.
AL2	Alarm 2 condition indicator.
REM	Setting by serial communication interface enabled.
PK H	“Peak high” indicator.
PK L	“Peak low” indicator.
LOCK	Parameters protection enabled.

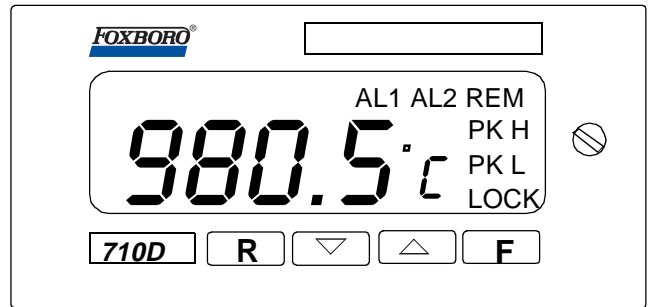

Button	Description
R	During configuration and calibration procedures or alarm threshold setting, scrolls back the parameters without memorization of the new values. Manually reset Alarm 1.
R +	Manually reset Alarm 1.
R +	Manually reset Alarm 2.
R + F	During configuration and calibration procedures or alarm threshold setting, loads the default parameters. Increases the parameter value.
	Increases the parameter value.
	Decreases the parameter value.
F	Selects any parameter, displays the parameters sequentially, and stores the value of the previously displayed parameter.

STANDARD SPECIFICATIONS

Housing

ABS black. Self-extinguishing degree V-O in accordance with UL, VDE, and CSA.

Agency Certification

These controllers have been designed to meet the safety standards of the European Union Directive symbolized by the “CE” logo. For detailed information or status of testing laboratory approvals/certifications, contact Foxboro.

Front Panel

Designed and tested for IP54 per IEC 529 and CEI 70-1

Installation

Panel mounting by means of brackets

Rear Terminal Block

Up to 21 screw terminals, with safety rear cover

Dimensions

48 x 96 mm (1.890 x 3.780 in) in accordance with DIN 43700; 149 mm (5.866 in) deep

Mass

600 grams (21 ounces) maximum

Power Supply (Switch Mode)

100 to 240 V ac
50/60 Hz (+10% /-15% of the nominal value)

Power Consumption

8 VA maximum

Insulation Resistance

>100 MΩ per IEC 348

Dielectric Strength

1500 Vrms per IEC 348

D/A Conversion

Dual slope integration

Noise Immunity

Electrical fast transient/burst requirements:
Severity Level 3 (according to IEC 801-4)

Sampling Time

100 ms typical

Accuracy

±0.1% full scale or span or ± 1 digit, @ 25 °C and nominal power supply voltage

Common Mode Rejection Ratio

120 dB @ 50/60 Hz

Normal Mode Rejection Ratio

60 dB @ 50/60 Hz

Temperature Drift

<200 ppm/°C of full scale (reference junction excluded)

Normal Operating Temperature Limits

0 to +50 °C (32 to 122 °F)

Storage Temperature Limits

-20 to +70 °C (-4 to +158 °F)

Relative Humidity Limits

20% to 85% RH, noncondensing

Protection

Watchdog circuit for automatic restart. Internal jumper for configuration and calibration parameters.

Universal Analog Input

All inputs are factory calibrated and selectable from the keyboard for one of three analog input types.

THERMOCOUPLE TYPE

B, E, J, Fe-CuNi, K, R, S, T, Cu-CuNi, N, W, W3, W5, Ni/Ni-Mo, and Platinel II, keyboard configurable

Standard Ranges

TC Type	Range	
	°F	°C
B	32/3300 (see Note 1)	0/1820 (see Note 1)
E	-328/1470	-199.9/800.0
J	-328/1830	-199.9/999.9
Fe-CuNi	-328/1650	-199.9/900.0
K	-328/2500	-199.9/1371 (see Note 2)
R	-58/3200	-50/1760
S	-58/3200	-50/1760
T	-328/750	-199.9/400.0
Cu-CuNi	328/1110	-199.9/600.0
N	32/2370	0/1300
W	32/4190	0/2310
W3	32/4190	0/2310
W5	32/4190	0/2310
Ni/Ni-Mo	32/2192	0/1200
Platinel II	14/2550	-10/1400

1. Accuracy guaranteed from 300 °C (570 °F).

2. Resolution 0.1 °C up to 999.9 °C.

Engineering Units

°C and °F, keyboard configurable

STANDARD SPECIFICATIONS (Continued)

Reference Junction

Automatic compensation for an ambient temperature between 0 and 50 °C

Line Resistance

100Ω maximum

Input Impedance

>1M Ω

Sensor Break

Downscale or upscale, programmable

Calibration

Per IEC 584-1

RTD TYPE

RTD, Pt 100Ω and Ni 100 Ω, 3-wire connection

Input Type	Range	
Pt 100 Ω RTD	-328/1560 °F	-199.9/850.0 °C
Ni 100 Ω RTD	-76/660 °F	-60/0.350.0 °C

Engineering Units

°C and °F keyboard configurable

Line Resistance

Automatic compensation up to 3 Ω/wire

Sensor Break

An overrange, upscale or downscale programmable

Calibration

Per DIN 43760

LINEAR INPUT TYPE

mA, mV, V, keyboard programmable

Input Impedance

Input Type	Input Impedance	Accuracy
00-60 mV	≥ 800 KΩ	0.1% ± 1 digit @ 25 °C
12-60 mV		
0-5 V	≥ 200 KΩ	
1-5 V		
0-10 V		
2-10 V		

Current Input

Input Type	Accuracy	Resolution
0-20 mA	0.1% ± 1 digit @ 25 °C	1 digit
4-20 mA		

Sensor Break

Downscale for current or voltage; upscale for millivoltage

Linearization

Up to 9 breakpoints (10 segments) can be programmed over the entire span

Square Root Extraction

Programmable throughout the input range

Logic Input

One logic input available with three types of input signals:

LOGIC VOLTAGE

Minimum differential signal = 3 V

Input maximum = 24 V

Maximum sink current = 5 mA at 24 V

Maximum source current = 2 mA at 0 V input

Input impedance = 10 kΩ

PROXIMITY 2 WIRES:

Power supply = max. 1 V

Maximum current = 4 mA

Minimum differential signal = 1.1 mA

PROXIMITY 3 WIRES:

Power supply = 9/18 (selectable by jumper)

Maximum current = 20 mA

Minimum differential signal = 1.1 mA with short circuit protection

Analog Retransmission Output

(not available with digital communications)

TYPE

Isolated 0-20 mA; 4-20 mA; or 0-10 V (programmable)

MAXIMUM LOAD (CURRENT OUTPUT)

500 Ω

MINIMUM LOAD (VOLTAGE OUTPUT)

5K Ω

OUTPUT RESOLUTION

±0.1% of full scale or span

ACCURACY

±0.2% of full scale or span. Note that this applies only to the retransmission circuit and does not take into account other errors.

Display Readout

Display range -1999 to 9999 programmable from the keyboard

STANDARD SPECIFICATIONS (Continued)

Digital Communications

(not available with retransmission output)

TYPE

Opto-isolated RS-485

PROTOCOL

Modbus

BAUD RATE

150, 300, 600, 1200, 2400, 4800, 9600, and 19,200

BYTE FORMAT

7 bits + parity bit

8 bits + parity bit

8 bits + no parity bit

PARITY

Even or Odd

STOP BIT

1 Stop bit

ADDRESS

From 0 to 31

Auxiliary Power Supply

VOLTAGE OUTPUT

Isolated 5, 10, 12 or 24 V dc (jumper selectable)

MAXIMUM CURRENT

25 mA dc

ACCURACY

± 5% of nominal

Special Functions

PEAK HIGH/PEAK LOW DETECTION

The instrument memorizes (and displays) the high and lowest detected reading.

ANALOG INPUT FILTER

A software filter can be applied to the measured value (available for alarms and retransmission signal also). The time constant of the filter is programmable from 0.4 to 5 s.

SECURITY SOFTWARE KEY

A programmable 4-digit code for protecting alarm set points.

Logic Input Functions

One input by external contact for:

- a. Holding the measured value
- b. Manual reset of the alarms

Safety Lock

For protection of the alarm threshold value

Dip Switch

Select between the three modes:

- Configuration mode
- Calibration mode
- Operative mode

Alarms

Two independent alarms available

ALARM TYPES

Programmable High or Low Process Alarms

ALARM RESET

Programmable Automatic or Manual (from front keys or by contact closure)

ALARM SET POINTS

Programmable from 0 to 100% of span

ALARM HYSTERESIS

0.1 - 5.0% of span

ALARM OUTPUTS

Two SPST relays, NO or NC (jumper selectable)

CONTACT RATINGS

2 A/ 30 V dc on a resistive load

0.6 A/ 110 V dc on a resistive load

0.5 A/ 250 V ac on a resistive load

0.3 A/ 110 V dc on an inductive load

MODEL CODE

710D=- 1/8 DIN Digital Indicator

Power Supply

3 = 100 to 240 V ac

5 = 24 V ac/dc

Inputs

9 = TC, mV, mA, V, RTD

Alarms

11= 2 Alarms

Options

1 = Auxiliary Power Supply

2 = mA Analog Retransmission and Auxiliary Power Supply

3 = RS-485 and Auxiliary Power Supply

4 = RS-485

5 = mA Analog Retransmission

Example: 710D-39112

DIMENSIONS - NOMINAL

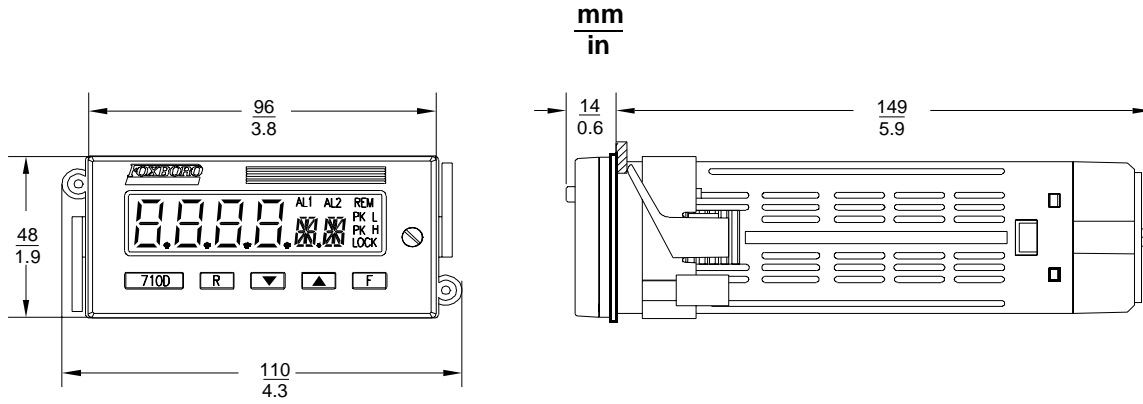

PANEL CUTOUT DIMENSIONS

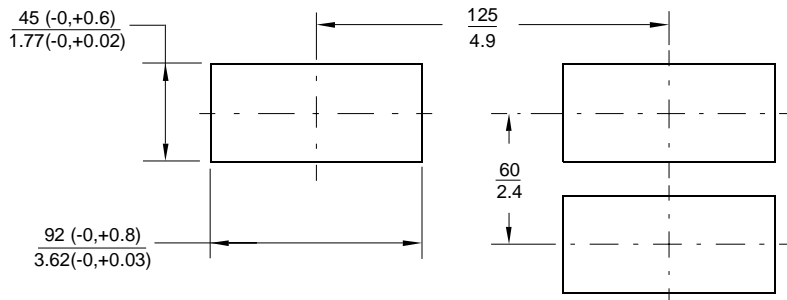

TERMINAL CONNECTIONS

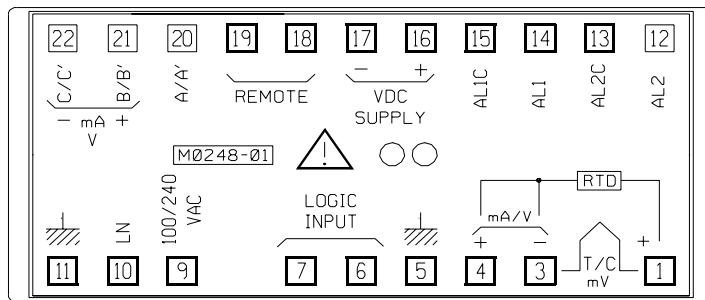

The Foxboro Company
 33 Commercial Street
 Foxboro
 Massachusetts 02035-2099
 Telephone (508) 543-8750
 Facsimile (508) 549-6750

A Siebe Group Company

Foxboro and I/A Series are registered trademarks of The Foxboro Company.
 Siebe is a registered trademark of Siebe, plc.
 Modbus is a trademark of AEG Schneider Automation, Inc.

Copyright 1996 by The Foxboro Company
 All rights reserved

MB 010

Printed in U.S.A.

1196